



South Fort Collins Sanitation District

Development and Design Specifications

1st Edition
Effective February 5, 2024

Table of Contents

Chapter 1 - General Provisions	1-1
1.1 Authority of This Document.....	1-1
1.2 Purpose and Additional Provisions.....	1-1
1.3 Authority	1-1
1.4 Revisions and Updated Specifications	1-2
1.5 Definitions of Terms and Abbreviations.....	1-2
1.6 Interpretation of Specifications.....	1-5
1.7 Enforcement and Inspection Responsibility.....	1-6
1.8 Safety and Protection.....	1-6
Chapter 2 – Development Process and Procedures	2-1
2.1 General.....	2-1
2.2 Conceptual Review	2-1
2.3 Inclusion	2-1
2.4 Will Serve Letter	2-1
2.5 Development Review	2-2
2.6 Final Design Drawings	2-2
2.7 Submittals and Preconstruction Meeting.....	2-2
2.8 Construction, Inspection and Testing	2-3
2.9 Substantial Completion	2-3
2.10 Warranty Period.....	2-4
2.11 Final Acceptance	2-4
Chapter 3 – Drawings	3-1
3.1 General.....	3-1
3.2 Datum.....	3-1
3.3 Construction Drawing Requirements.....	3-1
3.4 Plan and Profile View Requirements.....	3-4
3.5 Utility Details.....	3-5
3.6 Easements.....	3-5
3.7 Record Drawings	3-6
Chapter 4 – Design Criteria	4-1
4.1 General.....	4-1
4.2 Wastewater Impact Analysis Report	4-1
4.3 Criteria	4-2

4.4	Horizontal Layout.....	4-3
4.5	Depth.....	4-4
4.6	Alignments.....	4-4
4.7	Crossings.....	4-4
4.8	Manholes.....	4-5
4.9	Groundwater Barriers.....	4-6
4.10	Service Lines.....	4-7
4.11	Grease, Sand / Oil Interceptors.....	4-8
Chapter 5 – Trenching, Backfilling and Compaction.....		5-1
5.1	General.....	5-1
5.2	Materials.....	5-4
5.3	Construction.....	5-7
Chapter 6 – Materials and Installation.....		6-1
6.1	General.....	6-1
6.2	Materials: Pipe, Related Fittings and Appurtenances.....	6-1
6.3	Materials: Manholes.....	6-3
6.4	Construction and Installation.....	6-5
Chapter 7 - Testing Wastewater Systems.....		7-1
7.1	General.....	7-1
7.2	Inspection Procedures.....	7-1
7.3	Material/Soil Testing.....	7-2
7.4	Pipe Testing.....	7-2
7.5	Tracer Wire Testing.....	7-4
7.6	Manhole Testing.....	7-4
7.7	Video Recording Sewer Mains.....	7-5
7.8	Sags.....	7-6
Chapter 8 – Cast-In-Place Concrete.....		8-1
8.1	Scope.....	8-1
8.2	Materials.....	8-1
8.3	Construction.....	8-2
Chapter 9 – Precast Concrete.....		9-1
9.1	Scope.....	9-1
9.2	Materials.....	9-1
9.3	Construction.....	9-1

Chapter 10 – Adjustment of Manhole Rims.....	10-1
10.1 Responsibility.....	10-1
10.2 Notification.....	10-1
10.3 Description.....	10-1
10.4 Materials.....	10-1
10.5 Construction Requirements.....	10-2
10.6 Equipment	10-2

Appendices

Appendix A, Development and Construction Process

Appendix B, Development Drawing Checklist

Appendix C, Standard Drawings

Chapter 1 - General Provisions

1.1 Authority of This Document

This Document, with all future amendments, shall be known as the South Fort Collins Sanitation District (District) Development and Design Specifications (Specifications). These Specifications shall be the governing Specifications for all Wastewater Systems including those that are designed and installed in conjunction with the District's Development Review Process and are within the District Service Area. The final interpretation of these Specifications shall be made by the District.

These Specifications shall be the minimum criteria for planning, design, materials, installation, inspection, testing and documentation of Wastewater Systems within the District. Wastewater systems not covered by these Specifications, such as lift stations and force mains shall be reviewed and approved by the District on a case-by-case basis. Specifications for sand, oil and grease interceptors are described in other District documents.

1.2 Purpose and Additional Provisions

The purpose of this document is to set forth the Districts' criteria for the design and construction of sewer mains, service lines, manholes and all appurtenances associated with these mains and services. It is for the use of owners, developers, design engineers, and contractors for the construction of said mains, services, manholes and appurtenances.

The intent of these Specifications is to establish minimum acceptable criteria. The District may allow application or use of alternate and/or additional standards that are more stringent than these Specifications, with prior written approval. Any conflicts between the Specifications and Standard Drawings are unintentional and when requested in writing the District shall provide a letter of interpretation. If a conflict occurs between sanitary sewer mains, services and other utilities as identified during construction, the Contractor shall contact the District to interpret these Specifications or to determine if the specifications of other utilities or entities apply.

The District's review of plans, reports and drawings or the inspection of installation and construction of Wastewater Systems pursuant to these Specifications shall not constitute a representation, warranty or guarantee by the District that such systems are free from defects or will operate adequately for the purpose intended.

1.3 Authority

The District-elected Board of Directors has authorized a District Manager and their authorized representative, to have the authority on behalf of the District to determine that all planning, design, materials, installation, testing and documentation of Wastewater Systems are pursuant to these Specifications.

1.4 Revisions and Updated Specifications

The District will maintain and amend these Specifications and will post these Specifications and amendments on the District's website. The District does not keep a database of holders of these Specifications. Consequently, it shall be the responsibility of each holder to verify that the most current Specifications are being used.

1.5 Definitions of Terms and Abbreviations

When the following words, phrases, or abbreviations appear in these Specifications, they shall have the following definition and meaning:

AASHTO – American Association of State Highway and Transportation Officials

ACI – American Concrete Institute

Appurtenance- Any item, except Manholes, Sewer Mains and Service Lines that are attached and/or serve as a functional part of the Wastewater System.

ASTM – American Society for Testing and Materials

AWG – American Wire Gauge

CDOT – Colorado Department of Transportation

Construction Drawings – Drawings prepared by the Design Engineer, which depict materials, methods and other data required to install new wastewater systems and improvements pursuant to these Specifications. These Drawing will not be considered Final Construction Drawings until approved through the District's development review process and signed by the Design Engineer and the District Engineer.

Construction Staking – The act and use of material involved in the placement of identification markers. Such markers shall show horizontal and vertical location(s) of Wastewater Systems and all related appurtenances. All Construction Staking shall be performed by, or under the direct supervision of, a licensed Professional Land Surveyor in the State of Colorado.

Contractor – The person, firm or organization to whom a construction contract is awarded by the Developer to do work within a Development Project Area. Agents, employees, workers or sub-contractors employed by the Contractor are also bound by the terms of these Specifications.

Days – Intended as calendar days unless specifically stipulated otherwise as Working Days.

Design Engineer – The Professional [Civil] Engineer, licensed by the State of Colorado who signs the Final Construction Plans, as submitted through the District's Development Review Process. The Design Engineer shall also sign the Record Drawings.

Developer – The person or entity responsible for planning, design and installation of Public Wastewater Systems within Public Rights-of-way, Easements or within any portion of an approved Development Project Area.

Development – The use of any building, structure or land that includes modifying existing public wastewater infrastructure or the construction of new wastewater infrastructure. This includes new uses or accessory uses, expansions of existing uses or accessory uses, and material changes to the operational characteristics of existing uses or accessory uses.

Development Review Process – The process, pursuant to applicable City, Town or County codes, whereby certain residential, commercial and industrial development is regulated and approved.

Development Project Area – An area approved by the District for development or re-development, pursuant to the Specifications.

District – The South Fort Collins Sanitation District.

District Engineer - Shall mean the District Engineer of the South Fort Collins Sanitation District or their authorized representative.

District Inspector – An authorized representative of the District, assigned to make inspections to assure installation and materials are completed in compliance with these Specifications and Final Construction Plans.

Easement – A right granted to the District to use certain property for purposes of ownership, maintenance, access, inspection and other related incidentals associated with District Wastewater Systems. The right granted may be exclusive or non-exclusive, depending on the nature and situation within a Development Project Area. When not depicted on a Final Plat, the District shall require the use of separate approved easement agreements. The agreements must be obtained from the District before use, execution or recording.

Final Acceptance – The District’s documentation and process whereby notification is sent to the Developer/Contractor that the Warranty Period has been satisfactorily completed and that all public Wastewater Systems are fully accepted by the District. Such notification shall release the Developer/Contractor from future maintenance obligations.

Final Construction Drawings – Drawings prepared by the Design Engineer, which depict materials, methods and other data required to install new wastewater systems and improvements pursuant to these Specifications, approved through the District’s development review process and that have been signed by the Design Engineer and the District Engineer. Any revision to the Final Construction Drawings must be approved by the District and signed again by the Design Engineer and the District Engineer, which negates the earlier version of the Final Construction Drawings, so that only one version of the Final Construction Drawings shall be accepted.

Final Plat – A land surveying document depicting the subdivision of real property, normally accompanied by Final Construction Drawings.

GPM – Gallons Per Minute

Or Approved Equal - As approved by the District, in writing, to being equal.

OSHA – Occupational Safety and Health Administration

Pre-Construction Meeting – A meeting convened before beginning any Work within an approved Development Project Area. The meeting shall include the Developer/Contractor and the District's Inspector and shall facilitate the review of signed Final Construction Plans and any proposed Work necessary to install Wastewater Systems.

Provide - Furnish and install complete in place.

PSI – Pounds per Square Inch, a unit of pressure. PSI shall be considered gauge pressure (PSIG) unless otherwise noted.

Public Wastewater System – Wastewater facilities, improvements and related appurtenances that, upon Final Acceptance, are owned, operated and maintained by the District.

Punch List, Initial or Final – A written list of Work or material items compiled by the District Inspector, which do not conform to these Specifications, the Final Construction Plans or other associated Standards that govern the Development Project Area. The Developer/Contractor shall bring all such items into conformance with these Standards before either Substantial Completion or Final Acceptance.

PVC – Polyvinyl Chloride, a typical pipe material

Record Drawings – Final Construction Drawings, updated and certified by the Design Engineer, which depict actual materials, locations and dimensions of wastewater systems after construction and any modifications from the Final Construction Drawings.

Reimbursement Agreement – An agreement, between the Developer who initially installs certain Public Wastewater Systems, and the District, for the purpose of collecting reimbursement to the Developer from certain future Developers that may potentially connect to said Public Wastewater Systems.

Roadway – The portion of the highway, arterial, collector, or local street, including shoulders, intended for vehicle and/or bicycle use.

Service Line - All pipe, fittings and appurtenances for conveying wastewater from the customer's premises to the Sewer Main. Also known as a Service Lateral. Typically, the District does not own the Service Line.

Sewer – Sanitary sewer for conveying wastewater.

Sewer Main – All pipes owned by the District to convey wastewater.

Shall – A mandatory condition.

Should – An advisory condition, recommended, but not required.

Specifications – These Wastewater Development and Design Specifications, inclusive of all codes and other referenced standards, also known as Sanitary Sewer Standard Specifications.

Standard Drawings – Drawings included as part of these Specifications that depict typical and normal materials, certain installation methods and locations associated with a specific portion of the Wastewater System.

Structure – Any item constructed or erected with a fixed location below, upon, or above grade, including but not limited to any type of permanent foundation, traffic signal poles, fences, retaining walls, buildings, inlets, vaults, utility poles, bridges, drainage facilities.

Substantial Completion – Satisfactory completion of certain Work items within an approved Development Project Area, completion of all required testing, and District receipt of certain deliverables, which starts the two-year warranty period and allows the Developer to proceed with tap applications.

Surety – A financial instrument, such as cash, letter of credit, bond or escrow agreement as approved by the District, securing the Developer's responsibility to complete construction within an approved Development Project Area. Surety may also mean a financial instrument securing the Developers' obligations throughout the Warranty Period.

Tap - The physical connection of the Service Line to the Sewer Main.

Warranty Period – Starting from time of Substantial Completion, a period of two years that the Developer/Contractor is responsible for maintenance, and for material and workmanship defects in the Wastewater System, within an approved Development Project Area.

Wastewater System – All of the piping, manholes, taps and other connections and appurtenances necessary for the collection and conveyance of wastewater within a Development Project Area, or within the District Service Area.

Work – All installation and construction activity, including materials, labor, supervision and use of tools and equipment necessary to complete installation and construction of Wastewater Systems.

Working Day – Unless approved otherwise by the District, 8 a.m. to 5 p.m., Monday through Friday, excluding holidays observed by the District.

1.6 Interpretation of Specifications

- 1.6.1 These Specifications contain command sentences which are directed at the Design Engineer and/or Contractor unless otherwise stated.
- 1.6.2 The Design Engineer and/or Contractor shall request clarification in writing to the District, of all apparent conflicts. The District will not be responsible for any explanations, interpretations, or supplementary data provided by others.
- 1.6.3 The most recent version of District Specifications shall supersede any previous versions. It is the responsibility of the user of these Specifications to find and utilize the most recent version, as posted on the District website.
- 1.6.4 All items and work not covered by these specifications shall be discussed with the District, and the Contractor shall receive approval from the District, in writing, before beginning work.

1.7 Enforcement and Inspection Responsibility

These Specifications are enforceable by the District at any point in the Development process, including construction and inspection of Wastewater Systems.

1.8 Safety and Protection

- 1.8.1 The Contractor shall be responsible for initiating, maintaining and supervising all safety precautions and programs in connection with the work. The Contractor shall take all reasonable and necessary precautions for the safety of, and shall provide the necessary protection to prevent damage, injury or loss to:
 - a. Employees and other persons onsite who may be affected.
 - b. The work and materials or equipment to be incorporated therein, whether in storage on or off the site.
 - c. Other property at the site or adjacent thereto, including, but not limited to trees, shrubs, lawns, walks, pavements, roadways, structures and utilities not designated for removal, relocation or replacement in the course of construction.
- 1.8.2 The Contractor shall comply with all applicable laws, ordinances, rules, regulations and orders of any public body having jurisdiction for the safety of persons or property or to protect them from damage, injury or loss; and shall erect and maintain all necessary safeguards for such safety and protection.

Chapter 2 – Development Process and Procedures

2.1 General

The purpose of the District’s Development Review Process is to ensure that assets that the District will own and operate will provide economical and high level of service to the District customers. Development generally follows the process depicted in Appendix A as described below:

1. Conceptual Review
2. Inclusion
3. Will Serve Letter
4. Development Review
5. Final Design Drawings
6. Submittals and Preconstruction Meeting
7. Construction, Inspection and Testing
8. Substantial Completion
9. Warranty Period
10. Final Acceptance

2.2 Conceptual Review

Conceptual reviews may be conducted between the District and a Developer as a courtesy to the Developer and as general guidance, but do not constitute official review or approval of plans or calculations. Conceptual reviews are useful and recommended for all projects but not required.

2.3 Inclusion

Parcels that are within the District service area must be “included” to be served by the District and for tax purposes. The inclusion status of a parcel may be confirmed with the Larimer County Tax Assessor or by contacting the District. The inclusion process involves certain fees and processes described on the District website. Inclusion of any parcel is at the discretion of the Board.

2.4 Will Serve Letter

Some developers, for their own use, will request that the District provide a “Will Serve Letter” indicating the District’s intent to provide sanitary sewer service to a parcel. Providing this letter is at the discretion of the District Engineer and a Will Serve Letter does not guarantee inclusion or

service and does not negate the Development Review Process.

2.5 Development Review

- 2.5.1 **Process:** Development review is initiated through the referring entities of the City of Fort Collins, City of Loveland, Town of Windsor, Town of Timnath or Larimer County and the development review is referred to the District. District comments will be transmitted back to the Developer through the referring entity. This process does not preclude the Developer from direct contact with the District, but any decisions made outside of the Development Review Process must be documented through the Development Review Process to constitute official comments.
- 2.5.2 **Standards:** Refer to Chapter 3 for drawing requirements and Chapter 4 for design criteria.
- 2.5.2 **Expiration:** After District comments are returned and no further communication is received from the Developer for a period of two years, the Development Review Process must be re-initiated with the District which may result in new requirements. To capture all District-required changes, the development review process may need to be re-initiated with the referring entity.

2.6 Final Design Drawings

- 2.6.1 **Signature:** When all District comments have been addressed through the Development Review Process, the Developer may contact the District Engineer for signature. Once signed, the drawing will be considered the Final Design Drawings.
- 2.6.2 **Expiration:** Two years after the signature date, if the Developer has no further communication with the District, the District Engineer's signature becomes void and the Final Design Drawings will not be considered valid for the District, though they may remain valid for other entities. The drawings could be revalidated after meeting with the District Engineer, or the District Engineer could require a new comment and revision process before signing the drawings.

2.7 Submittals and Preconstruction Meeting

- 2.7.1 **Submittals:** The Developer or their Contractor must notify the District of their intent to begin construction and supply the following submittals before scheduling a required preconstruction meeting:
- a. **Drawings:** A PDF of final design drawings signed by all parties.
 - b. **Easements:** A PDF of the recorded plat with easements and records of any other easement filings. All required easements must have been legally filed before the preconstruction meeting may be scheduled, including easements crossing railroad or ditch properties or rights-of-way. Any terms, covenants, and conditions of easement agreements must be transferrable to successors and assigns.

- c. **Taps:** A list of all taps for the project in the District spreadsheet format.
- d. **Materials:** Submittals for all materials to be used.
- e. **Drawing Print:** One printed 11 X 17 set of construction drawings, which may be delivered at the preconstruction meeting.

2.7.2 **Preconstruction Meeting:** A Preconstruction Meeting shall occur between the District and the Developer/Contractor. It is the responsibility of the Developer/Contractor to schedule the meeting with the District Inspector.

2.8 Construction, Inspection and Testing

- 2.8.1 As construction progresses, the Contractor must periodically contact the District Inspector in advance of any stage of construction to be inspected. All sewer infrastructure including service lines must be inspected and must pass testing described in Chapter 7 of these Specifications.
- 2.8.2 When all sewer infrastructure has been installed, including all-weather access to every manhole, the Contractor must clean and digitally record all sewer lines and manholes and provide the recordings to the District Inspector. Recordings must meet the requirements of section 7.5 of these Specifications.
- 2.8.3 Once all construction and recording are completed to the satisfaction of the District Inspector, the Contractor or Developer may apply for Substantial Completion.
- 2.8.4 All Taps to existing Sewer Mains shall be inspected before burial.

2.9 Substantial Completion

- 2.9.1 Once all infrastructure has been installed and approved by the District, and all punch list items have been addressed, the developer may request Substantial Completion for the project.
- 2.9.1 To receive a status of Substantial Completion, the District must receive:
 - a. **Letter Request:** The letter must request Substantial Completion and include the value of the public portion of the sewer infrastructure.
 - b. **As-built Record Drawings:** Shall meet the requirement in section 3.7.
- 2.9.2 When all requirements have been met, the District Engineer will issue a letter of Substantial Completion.
 - a. The District will begin providing Utility Locates for the Sewer Mains.
 - b. The Developer may apply to purchase Sewer Taps in accordance with procedures on the District Website.
 - c. A Substantial Completion status is not a guarantee that taps may be sold. Tap

sales may be withheld for a variety of reasons including unresolved issues discovered during the warranty period and unpaid reimbursements.

2.10 Warranty Period

- 2.10.1 During the warranty period, the Developer shall be responsible for all repairs and maintenance of the Wastewater System to maintain a new condition and prevent clogs, backups and overflows.
- 2.10.2 During the warranty period, the Developer shall respond promptly to reports of any issues with the Wastewater System.
- 2.10.3 The warranty period shall extend for a minimum of two years after Substantial Completion and will continue to extend until all District requirements are met and Final Acceptance has been granted.
- 2.10.4 At any time during the Warranty Period the District may notify the Developer of needed repairs.
 - a. If the repair areas are an imminent danger to public health, safety, and welfare, the Developer shall act within twenty-four (24) hours to complete the repair.
 - b. If the work is not considered a safety issue, the Developer has 10 working days to schedule the work, and sixty (60) calendar days to complete the work. Time extensions may be granted due to weather constraints.
 - c. If the Developer does not complete the warranty repairs in the time specified, the District may choose to make the repairs. If so, the District will invoice the Developer for any costs for the related work plus an administrative fee.

2.11 Final Acceptance

To be granted the status of Final Acceptance after the two-year minimum warranty period, the following must be complete:

- 2.11.1 The Developer shall clean the Wastewater System and digitally record all manholes and Sewer Mains in accordance with the requirements in Section 7.7.
- 2.11.2 The Developer shall provide the digital records to the District Inspector who will review the records and approve or disapprove of the system cleanliness, the quality of the recordings and the physical condition of the Wastewater System.
- 2.11.3 The Developer shall continue to correct all deficiencies noted by the District Inspector and resubmit recordings as needed until all Wastewater System conditions are to the satisfaction of the District Inspector at which time the District Engineer will issue a letter granting Final Acceptance.
- 2.11.4 Upon Final Acceptance, the District will take ownership of the Wastewater System and its permanent maintenance.

Chapter 3 – Drawings

3.1 General

- 3.1.2 All Final Construction Drawings and Record Drawings shall be signed and sealed by a Colorado Professional Engineer (Design Engineer) in accordance with the most recent Bylaws and Rules of the State Board of Licensure for Professional Engineers and Professional Land Surveyors.
- 3.1.3 To aid in the preparation of Construction Drawings, a Development Drawing Checklist is included in Appendix B. The checklist is not required, but it is recommended to be submitted with all Construction Drawings as it will tend to:
- Reduce design errors.
 - Reduce development review time and iterations.
 - Serve as a point of reference for comments and items to meet design approval.
- 3.1.4 Expiration of Plan Set – Final Construction Drawings shall be valid for a period of two years from the date of signature by the District Engineer.

3.2 Datum

- 3.2.1 **Vertical Datum:** Construction Plans shall reference the North American Vertical Datum of 1988 (NAVD 88).
- 3.2.2 **Horizontal Coordinate System:** Shall be based on Colorado State Plane North Coordinates NAD83 (2011) datum and be submitted in ground coordinates using a combined scale factor of 0.99973203 (1.00026804) about the origin 0,0.

3.3 Construction Drawing Requirements

- 3.3.1 All Construction Drawings shall contain the District signature block:

SOUTH FORT COLLINS SANITATION DISTRICT	
_____ District Engineer	_____ Date
<small>All changes, addendums, additions, deletions and modifications to these drawings must be approved, in writing, by the South Fort Collins Sanitation District.</small>	

- 3.3.2 The following specific notes shall be printed in the Construction Drawing set, typically on a stand-alone notes sheet or on the utility plan sheet.

South Fort Collins Sanitation District Notes:

1. All sanitary sewer construction shall be performed according to South Fort Collins Sanitation District Specifications.
2. In cases of conflict between these signed construction drawings and the District Specifications, the standard detail drawings, and/or other standards, the most restrictive standards shall apply.
3. Construction of sewer facilities requires a pre-construction meeting with the District Inspector before commencing construction.
4. Contractor shall notify the District Inspector before starting work.
5. Contractor shall contact the District Inspector for inspection at least two working days before new work is to be inspected, including connecting to existing sewer stubs.
6. Pipe pressure and manhole vacuum testing shall be witnessed by the District Inspector.
7. As-built record drawings shall be submitted in .pdf and .dwg formats to the District for final approval.
8. Once the system is operational, proof of easement recording has been received by the District, record drawings have been received by the District, and all tests have passed, contractor shall request Substantial Completion with a letter to the District that includes the dollar value of the sewer improvements to be owned by the District.
9. Upon granting Substantial Completion, the two year warranty period will commence. Refer to District Specifications for requirements during and at the end of the warranty period.
10. Final Construction Drawings signed by the District Engineer will only be valid for a period of two years until the initiation of construction or other arrangements are made with the District.

- 3.3.3 Drawing sheet(s) shall be numbered sequentially, clearly integrated into the overall Construction Drawings, and shall depict all applicable notes.
- 3.3.4 Plan and profile sheet(s) are required for all sizes of Wastewater Systems. Plan view scale may be 1 inch = 50 feet, 40 feet, or larger with profile view scale shown with consistent and relative units to the plan view scale.
- 3.3.5 All construction and/or sequence phasing shall be clearly annotated such that each phase is depicted in a “stand alone” manner.

- 3.3.6 Existing and proposed property, Rights-of-way, Easements and Tract lines that are adjacent and/or encompass the proposed Wastewater System must be shown. All such lines shall be consistent with a proposed or recorded Final Plat or other lawful property description instrument, duly recorded with Larimer County. All lines shall be clearly referenced and dimensioned relative to one another. In some cases, Wastewater Systems may be required to extend beyond a particular phase. In these cases, Construction Drawings shall clearly show all applicable phase lines, design, details, rights-of-way, Easements and any other items necessary to properly accommodate such extension beyond a particular phase.
- 3.3.7 Longitudinal stationing shall be based on centerline of main for all Wastewater Systems appurtenances including Service Lines and Manholes. Stationing shall typically read in ascending order from the downstream manhole to the upstream manhole.
- 3.3.8 Horizontal locations for all proposed and existing Wastewater Systems shall be identified by linear dimensions or offset stationing to centerline of rights-of-way, Easements or tracts. In some cases, additional horizontal dimensioning may be required for purposes of clarity and further reference. Horizontal bearings and distances may also be used in conjunction with linear dimensioning. Horizontal coordinates (northing/easting) will not be allowed, except in cases of open fields or larger parking areas.
- 3.3.9 Roadway, right-of-way and/or access-way names shall be in a bold font.
- 3.3.10 Proposed finished surface contours shall be shown in area(s) over and nearby all proposed Wastewater Systems. This requirement is especially critical for areas beyond the typical street section such as from back of curb or walk towards private property.
- 3.3.11 Existing structures, dry and wet utilities and ground surfaces (shown as phantom lines and shapes) shall be shown. All existing items shall be dimensioned in a manner that clearly shows their relationship to all portions of proposed Wastewater Systems. Examples of existing items include but are not limited to the following:
- a. Water, wastewater, irrigation water, reclaimed water, storm drainage, electrical, cable television, communications, gas, oil, steam, petroleum, traffic control devices and any related appurtenances.
 - b. Overhead power or communication lines.
 - c. Existing ground contours.
 - d. Fence lines and gates.
 - e. Ditches or swales with contour lines.
 - f. Curbs and gutters, sidewalks, cross pans.
 - g. Pavement limits.
 - h. Bridges or culverts.

- i. Guardrails.
- j. Signs.
- k. Landscape features (trees, shrubs, hedges, turf, flowerbeds, etc.).
- l. Other items deemed appropriate by the District.

3.4 Plan and Profile View Requirements

3.4.1 Plan views shall include the following:

- a. Manholes with diameters and designation numbers/letters.
- b. Type and class of pipe material, length, diameter, and slopes for all Sewer Mains.
- c. Type of pipe material, length, diameter, slopes, and longitudinal stationing at connection points to the Sewer Main for all Service Lines.
- d. Grease interceptors, with stationing and horizontal ties.
- e. Sand and oil interceptors.
- f. Other wastewater appurtenances associated with the design.
- g. Match lines with stationing and sheet numbering.
- h. Construction phase lines with relative stationing.

3.4.2 Profile views shall include the following:

- a. Existing ground contour profile; dashed and denoted as such.
- b. Proposed finished grade contour profile, solid line and denoted as such.
- c. Existing structures, dry and wet utilities, with elevations and sizes.
- d. Longitudinal stationing for all manholes and other related appurtenances.
- e. Rim and all inflow and outflow invert elevations for each manhole, including existing manholes.
- f. Length, diameter and slope for all Sewer Mains.
- g. Longitudinal stationing for each groundwater barrier/cut-off wall.
- h. Vertical clearance dimensions between the proposed main and any existing or proposed nearby or conflicting structure or utility.
- i. Longitudinal station for each Service Line connection to the Sewer Main.

- j. Limits of special bedding, if required.
- k. Groundwater limits per approved geotechnical report
- l. Construction phase lines with relative stationing.

3.5 Utility Details

- 3.5.1 Appendix C includes Standard Drawings; these drawings shall be used when typical scenarios for design and construction warrant such use. When used, Standard Drawings shall be annotated onto Utility Detail sheet(s) of a Construction Drawing set and referenced on each applicable drawing sheet. Each Standard Drawing depicted on Utility Detail sheet(s) shall include the entire content of the original approved drawing including borders, title blocks, dates and notes.
- 3.5.2 Non-standard design for Wastewater Systems such as crossings, special fittings, casings, encasements and borings shall be depicted on the appropriate plan and/or profile sheet(s).

3.6 Easements

Easements shall encompass all portions of the Wastewater System that may extend beyond or outside a platted right-of-way. Easements, when dedicated by a Final Plat, shall be designated as public utility Easements, exclusively for the Wastewater System. Alternately, Easements conveyed by separate instrument shall be granted pursuant to the District's easement agreement forms.

- 3.6.1 Width of Easement and Sewer Main Location.
 - a. **Width:** The minimum Easement width shall be 30 feet or twice the depth to the deepest pipe invert, whichever is greater. In no case shall a Sewer Main or related appurtenance be located closer than 10 feet to the nearest Easement or private lot line.
 - b. **Between Lots:** Sewer Mains located between two private lots shall be placed within an Easement. The Easement shall be situated entirely on one lot or the other with the Sewer Main centered within the Easement.
 - c. **Additional Sewer Mains:** Easements containing more than one Sewer Main shall be increased by an additional 10 feet for each additional Sewer Main.
- 3.6.2 Manholes and Other Appurtenances
 - a. Manholes and other related appurtenances shall generally be centered within a designated Easement. All Easements shall extend a minimum of 10 feet beyond all sides of any manhole and other related Wastewater System appurtenances.
- 3.6.3 Restrictions within Easements

- a. **Allowed Improvements:** Pavement, sidewalks, bike paths, minor swales and berms and certain landscape features may be allowed within an Easement that encompasses a Sewer Main or appurtenance.
- b. **Landscaping Restrictions:** Landscaping shall be restricted as stated on the recorded easement. At a minimum, trees shall not be planted within any Easement. The District will not be responsible for damage to shrubs and exotic plantings within an Easement.
- c. **Prohibited Improvements:** Structures including permanent concrete base “kiosk” or clustered mailboxes, sheds, overhanging decks, buildings (with permanent or temporary foundations), permanent fences and other structures, shall not be allowed within any portion of an Easement designated to encompass a Wastewater System.

3.6.4 Access

- a. Easements alone may not provide adequate access to Sewer Mains and manholes for long-term maintenance and repair, and additional easements and all-weather roadways may be required.

3.7 Record Drawings

3.7.1 Required

- a. Record Drawings shall be submitted by the Design Engineer to the District Engineer for review and approval. Each drawing shall be labeled "DRAWINGS OF RECORD" in large letters, stamped and signed by the Design Engineer who shall be registered as a P.E. in the State of Colorado. Generally, Record Drawings are required for all Sewer Mains, Service Lines and manholes.
- b. Record Drawings are not required for a project with a single Service Line and tap, but the tap must still be surveyed at the connection to the Sewer Main and the Service Line must be surveyed near where it crosses into private property.

3.7.2 **Maintenance** of Construction Drawings and Other Documents by the Contractor (for use in submitting Record Drawings):

- a. Record Drawings and any documents used for the preparation of said drawings shall be stored apart from documents used for construction.
- b. Record Drawings and other documents shall be maintained in a clean, dry, legible condition and in good order.
- c. Changes or revisions from the Final Construction Drawings should be recorded concurrently, as installation progresses.
- d. All Final Construction Drawings and other documents used to prepare Record Drawings shall be available for review by the District Inspector upon request.

3.7.3 **Content** of Record Drawings

- a. The Record Drawings shall be updated with all design changes that occurred after plan approval.
- b. Record Drawings shall include, at a minimum, the following:
 - Dimensions, locations, grades/slopes, lengths, elevations and details that were changed, added or removed from that shown on the Final Construction Drawings.
 - Any details which are not on the original approved Final Construction Drawings.
 - Horizontal and vertical locations of underground utilities and appurtenances that were not shown on the final approved drawings, referenced to a minimum of three permanent surface improvements.
 - All dimensions shall be referenced to surveyed property corners if surface improvements have not been constructed.
 - All changes and revisions shall be marked legibly in red and shall be denoted by clouding, boxes or other visible ways of clarifying the change or revision.
- c. Record Drawings shall be prepared by the Design Engineer.
- d. Record Drawings shall include a copy of the originally signed Final Construction Drawings title sheet, and all sheets related to the Wastewater Systems.
- e. Include notation that the Colorado State Plane North NAD83 (2011) coordinate system and the NAVD88 vertical datum were utilized.
- f. Each Sheet (including the title sheet) must be clearly labeled **RECORD DRAWING** in bold font. Below or very near the **RECORD DRAWING** label, a statement, signed and sealed by the Design Engineer, must be annotated as follows: I _____ certify all Wastewater System improvements shown herein, including any noted changes or revisions, are in general conformance with the design/construction documents, pursuant to this Record Drawing copy of the Final Construction Drawings.

3.7.4 **Submittal** of Record Drawings. The following shall be submitted to the District Engineer for review and approval:

- a. Submit one electronic file in PDF format and one electronic file in AutoCAD (.dwg) format. The PDF must contain the horizontal and vertical coordinate information clearly stated on the front page. The DWG must be exported to version 2013, 2018, or a version compatible with Esri software and approved by SFCSD.
- b. Do not submit paper copies of Record Drawings.

- c. Submit to Engineering@SFCSD.net. If the combination of the two files exceeds 20 mB, deliver the two files on a portable flash memory device.
- d. The Substantial Completion status of the Wastewater System will not be granted until all District requirements are satisfied, and the Record Drawings are received and accepted by the District.
- e. Once no further changes are required to the Record Drawings, said drawings shall remain property of the District.

Chapter 4 – Design Criteria

4.1 General

This chapter specifies the minimum standards necessary for system analysis, layout and design of Wastewater Systems. Early collaboration with the District is recommended to incorporate District Wastewater System modelling and master planning. All Wastewater Systems shall conform to these Specifications, the most current version of the Wastewater Master Plan and other applicable Codes and Specifications approved by the District. It is critically important that Wastewater Systems be designed in a manner that accommodates acceptable access for future maintenance.

4.2 Wastewater Impact Analysis Report

4.2.1 **Requirement:** In conjunction with the development review process, the District requires the Design Engineer to submit a wastewater impact and demand analysis report. The report may take the form of a memo. In some circumstances and upon written request, the District Engineer may exempt small developments from the report requirement.

4.2.2 **Location:** Identify the location of the Development Project Area, the nature of the proposed development, the area Master Plan analysis, proposed zoning and the land use.

4.2.3 **Map:**

- a. Map scale (max 1" = 200 ft.), north arrow, vicinity map
- b. Proposed and existing easements and rights-of-way
- c. Offsite Sewer Mains and future areas that could be serviced, if applicable.
- d. Topography, utility crossings, and any proposed lift stations.
- e. Other existing and proposed utilities that might affect the proposed system layout or performance.

4.2.4 **Density:** Provide the proposed density (dwelling units/acre).

4.2.5 **Connection:** Identify proposed connection point(s) to the District wastewater system and identify any offsite areas contributing to the flow.

4.2.6 **Hydraulic Analysis:**

- a. Wastewater demands for all initial and future phases.
- b. Data table with pipe segments, inverts, depths, slopes, minimum and maximum design flow rates, minimum and maximum velocity, and maximum d/D

- c. Large area analysis: the design shall consider the length of pipe and time of concentration within the system.
- d. Minimum hydraulic performance for allowable depth and velocity.

4.2.7 **Geotechnical Report**: When required through the Development Review Process, and where applicable, a geotechnical report shall identify mitigation measures necessary for trench/bedding and stabilization not specifically addressed in these Specifications and address any high groundwater condition including pipe/manhole buoyancy and need for additional groundwater barriers.

4.3 Criteria

- 4.3.1 **Design Flow**: The wastewater design flow shall be the daily peak flow plus wet weather infiltration and inflow. Downstream of a lift station force main, the maximum pumping rate must also be included.
- 4.3.2 **Calculation**: Manning's Equation shall be used to compute the required pipe size, with a roughness coefficient (n) of 0.013.
- 4.3.3 **Velocity**: Minimum 2 ft/sec, maximum 7 ft/sec.
- 4.3.4 **Depth Ratio Minimum (d/D)**: ≤15-inch pipe: 0.5, >15 inch pipe: 0.75
- 4.3.5 **Minimum Sizes**: The minimum size for any Sewer Main is 8 inch. The minimum private service size is 4 inch.
- 4.3.6 **Peak Factor**: Shall be 3.
- 4.3.7 **Average Daily Flow (ADF)**

Land Use	Criteria
All Residential	80 gpd/capita
Single Family Residential Single Family Attached	3.2 capita/dwelling unit
Multi-Family (≥3 units)	2.8 capita/dwelling unit
Retail, Offices	0.2 gpd/sq ft
Hotels (meeting space, add 0.6 gpd/sq ft)	75 gpd/guest room
Commercial, Industrial, Institutional, Churches and Others	Considered case-by-case

4.3.8 **Pipe Slope**

	Pipe Diameter (inches)	Minimum Slope (Percent)	Maximum Slope (Percent)
Service	4	2.0	12
Lines	6	1.0	10
Sewer	8	0.40	8.3
Mains	10	0.28	6.2
	12	0.22	4.9
	15	0.15	3.6
	18	0.12	2.8
	21	0.10	2.3
	24	0.08	1.9

4.3.9 **Material:** all Sewer Mains shall be SDR 35 PVC unless otherwise approved.

4.4 Horizontal Layout

4.4.1 **Location:** Within the platted right-of-way or easement, Sewer Main(s) should be located at the centerline of the right-of-way or easement. In cases where a raised median is proposed, the Sewer Main shall be located outside of the raised median flow-line. Manholes should be located such that they are not within the wheel travel path of vehicles and in no case be located closer than 5 feet to the lip of curb and gutter.

4.4.2 **Separation**

- a. Water and storm drains shall be located a minimum of 10 feet horizontally clear from any portion of the wastewater system.
- b. Dry utilities (natural gas, electric, cable TV, and telephone/communications and all appurtenances) shall not be closer than 6 feet (outside edge to outside edge) to any portion of the Wastewater System.
- c. Curb, gutter, sidewalks, medians and other minor structures: Shall be located a minimum of 10 feet from any proposed Sewer Main, manhole and related appurtenance, unless crossed perpendicular. The District may require a casing pipe when crossing perpendicular to major curbed medians or other major structures.
- d. Landscape features: The outside edge of any shrub or bush (upon maturity) shall not be allowed within 5 feet of the nearest outside edge of Wastewater Systems. The outside edge of any tree trunk (upon maturity) shall not be allowed within 10 feet of the nearest outside edge of Wastewater Systems.
- e. Berms greater than 2 feet high and/or with side slopes steeper than 4:1 shall not be allowed within 10 feet of a Sewer Main and/or any related appurtenance.

- f. Signs, walls, and other structures shall not be allowed within 10 feet of Wastewater Systems.
- g. Easements may have additional separation or exclusion requirements.

4.5 Depth

- 4.5.1 **Cover:** Normal bury depth for Sewer Mains is 10 feet of cover from finish grade to top-of-pipe. Minimum depth of cover shall be 4 feet, as measured from finished grade to top-of-pipe.
- 4.5.2 **Deep Sewer Mains:** When Sewer Mains have greater than 20 feet of cover, calculations shall be submitted by the Design Engineer showing the proposed pipe material and bedding design is adequate, from a short and long term structural standpoint.

4.6 Alignments

- 4.6.1 **Straight:** Sewer Mains shall be laid with straight alignments between manholes. Joint deflection shall not be allowed.
- 4.6.2 **End of Run:** All runs shall end in a manhole, including runs that may terminate at a future construction phase line.
- 4.6.3 **Cul-De-Sac:** Sewer Mains shall be extended to an acceptable point within the cul-de-sac and terminated in a manhole.
- 4.6.4 **Last Lot:** Sewer Mains shall extend at least 10 feet past the nearest lot corner of the last lot to be served by the Wastewater System and terminated in a manhole.

4.7 Crossings

- 4.7.1 **General:** When a Sewer Main crosses another public or private utility, irrigation or drainage ditch, the crossing design shall protect the Sewer Main and utility's structural integrity, and mitigate future system impacts and costs of repair in a manner acceptable to the District. The agency responsible for the utility, ditch, railroad or other structure crossed may also impose additional criteria.

The vertical clearance requirements listed below may be modified with prior approval from the District and may require special backfill and/or casing requirements. Sewer Mains crossing under large utilities (24 inch and larger) may be required to be installed in a steel casing pipe.

- 4.7.2 **Water Systems:** Wastewater Systems shall cross beneath potable or raw water systems unless otherwise approved by the District and the water utility. An 18-inch vertical separation must be maintained unless otherwise approved by the District and the water utility.

- 4.7.3 **Storm Drain Systems.** When a Sewer Main crosses a storm drain system, the Sewer Main shall maintain a minimum 18 inch vertical clearance from the storm drain.
- 4.7.4 **Ditch Crossings:** Crossings with named ditch companies must receive their approval of each crossing. In addition to the requirements of these Specifications, the Ditch Company may modify or add to the requirements of these Specifications, provided the requirements are more stringent. All ditches shall be restored according to the ditch owner's criteria. All ditch, waterway and drainage crossings shall be designed with sufficient burial and/or encasement to prevent wash out.

4.8 Manholes

- 4.8.1 **Access Roads:** Permanent unobstructed access to every manhole is required via an all-weather driveway, either paved or gravel, designed for heavy truck loads. Driveways outside of street rights-of-way shall be a minimum of 15 feet wide and constructed to support maintenance vehicles weighing 40 tons.
- 4.8.2 **Depth:** Manholes exceeding 20 feet in depth must be justified in writing, specifically approved by the District, and specifically designed by the Design Engineer.
- 4.8.3 **Placement**
- a. **Spacing:** Maximum spacing between manholes shall be 500 feet with typical spacing at 400 feet.
 - b. **Points of Change:** Manholes shall be placed at every change in direction, grade and size of Sewer Main, and at connections to existing Sewer Mains. Manholes shall typically not be allowed to have less than a 90 degree angle between the incoming and outgoing Sewer Mains.
 - c. **End of Runs:** Manholes shall be placed at the end of all Sewer Main runs, regardless of permanent or temporary status. All end-of-run manholes, where a future Sewer Main extension is anticipated, shall be a precast base with no invert inlet penetration, no channel and no bench.
 - d. **Location:** Manholes should not be located in the traveled-way/wheel path of a paved public street.
 - e. **Fields:** Manholes on runs crossing field areas may be buried only with prior District approval. Bury depth shall not exceed 2 feet. Field markers shall be used to designate locations.
- 4.8.4 **Watertight:** Manholes shall not be placed in areas subject to surface runoff, flooding or ponding without specific District approval. If placement of manholes within these areas cannot be avoided, all barrel, cone and base joints shall be permanently waterproofed with a permanent exterior membrane in addition to standard water resistant requirements, and shall also have watertight ring and covers. Membrane wrap shall be approved by the District Engineer.

- 4.8.5 **Locking Lid:** Manholes placed within areas designated by the District as “restricted access”, shall have a locking lid with the rim permanently bolted to the manhole cone section.
- 4.8.6 **Size:** Manholes shall be sized according to Standard Drawing SS-1. Sizes are minimums, based on straight-through alignments. Larger manholes may be required to accommodate multiple incoming Sewer Mains or large radius horizontal flow-line channel bends.
- 4.8.7 **Inverts:** Manholes shall have a minimum 0.1 feet flow-line channel drop. Manholes with horizontal flow-line channel bends between 45 degrees and 75 degrees from the exit alignment shall have a minimum 0.2 foot flow-line channel drop. Manholes with flow-line channel bends between 75 degrees and 90 degrees from the exit alignment shall have a minimum 0.3 foot flow-line channel drop.
- 4.8.8 **Size Change:** When a smaller Sewer Main joins a larger Sewer Main, the mains shall be typically set such that elevation of the crowns of the two pipes are equal.
- 4.8.9 **Drop Manholes:** Drop manholes are discouraged but may be allowed on a case-by-case basis. Before approval of a drop manhole, the Design Engineer must provide alternatives for review and consideration by the District. If approved, drop manholes shall be designed as shown in Standard Drawing SS-6.
- 4.8.10 **Hydrogen Sulfide Resistance:** Manholes located in areas with a high probability of hydrogen sulfide corrosion shall be constructed with, or coated with, Hydrogen Sulfide resistant materials approved by the District. Typical locations for such manholes include, at force-main discharge points, drop manholes or on large diameter Sewer Mains with turbulent flows.
- a. A calming manhole shall be located at the terminus of a force main and shall be coated with Hydrogen Sulfide resistant materials. If the force main is privately owned and maintained then the Calming Manhole shall also be private, with the public portion beginning at the gravity outlet of the Calming Manhole.
 - b. The number of manholes to be coated with Hydrogen Sulfide resistant materials downstream of a calming manhole is two at a minimum. The District may require additional manholes to be coated.
 - c. District-approved hydrogen sulfide resistant materials are listed in Appendix D.

4.9 Groundwater Barriers

- 4.9.1 Groundwater barriers shall be installed with all Wastewater Systems. See Standard Drawing SS-11.
- 4.9.2 Groundwater barriers shall be designed to impede passage of groundwater through the entire portion of the excavated trench.

- 4.9.3 Groundwater barriers are typically located upstream of wastewater manholes. Groundwater barriers shall be spaced a maximum distance of 400 feet apart.
- 4.9.4 Groundwater barriers shall extend through the full depth of the granular bedding/pipe zone material and project 1 foot beyond each side of the trench wall. Groundwater barriers shall extend to the maximum of:
 - a. One foot above top of pipe bedding
 - b. Two feet above top of pipe
 - c. Two feet above the maximum seasonal groundwater table elevation.
- 4.9.5 Groundwater barriers/walls shall be installed on both sides of any natural waterway, pond/lake, or irrigation ditch. Other requirements may apply due to specific criteria from each ditch company.

4.10 Service Lines

- 4.10.1 **General:** All wastewater Service Lines, from the point of connection (including the physical connection joint to a Sewer Main or to a manufactured wye/saddle) into a residential, commercial or industrial building, shall be owned and maintained by the respective building and/or property owner. All Service Lines shall connect to the Sewer Main unless otherwise approved. The District may require a commercial or industrial facility to install a private manhole before connection to the Sewer Main.
- 4.10.2 **Materials:** Service lines shall meet the plumbing code for the applicable City, Town or County jurisdiction.
- 4.10.3 **Location/Size**
 - a. Typically, Service Line sizes are 4 or 6 inch diameter. Lines 8 inch and larger are generally regarded as being part of the Wastewater System. See Standard Drawings SS-7 and SS-8.
 - b. Service lines shall not connect into any manhole without special permission of the District. If allowed by special permission, the maximum number of Service Line connections to a manhole is 2.
 - c. Within the right-of-way or easement the Service Lines shall be located a minimum of 10 feet clear from any portion of a Public Water System (measured between the closest edges).
 - d. Service lines shall not cross any portion of an adjacent private lot without being situated in a private easement.
 - e. The Service Line shall not be installed less than 24 inches below finished grade.

- 4.10.4 **Service Types/Scenarios:** Notwithstanding requirements of the applicable City Town or County jurisdiction, the following service scenarios shall also apply.
- a. Residential Single Family, Duplex, Townhome: A type of dwelling unit whereby each unit is situated upon its own separate, platted lot, shall be serviced individually by one Service Line for each platted lot.
 - b. Residential Multi-Family: A type of dwelling unit containing 3 or more residences whereby each residence is not situated upon its own separate, platted lot, shall be serviced by one common private service line.
 - c. Commercial: A building with one or more internal tenant spaces whereby each tenant space is not situated on its own separate, platted lot shall be serviced by one common private service line for the entire building.
 - d. Industrial: Considered on a case-by-case basis.
- 4.10.5 **Private Mains:** Typically, all mains 8-inch and larger shall be considered public. Any Service Line that is upsized to 8-inch or larger based on slope concerns is still considered a private service. Because private wastewater systems are connected to the District wastewater system, all private mains and manholes shall be installed per District criteria and testing requirements. Inspection results will need to be provided to the District Inspector before initial acceptance.

4.11 Grease, Sand / Oil Interceptors

- 4.11.1 All commercial developments are subject to review for potential pretreatment requirements. At a minimum, this includes the submission of a Pretreatment Questionnaire as found on the District website. Failure to comply with the District's pretreatment policy may result in delays and may prohibit the project from reaching Substantial Completion or Final Acceptance.
- 4.11.2 Grease, Sand/Oil interceptor requirements are described in the District's separate Oil/Sand Policy available on the District website.

Chapter 5 – Trenching, Backfilling and Compaction

5.1 General

5.1.1 Scope:

- a. This section addresses excavation and trenching; including preparation of subgrades, pipe bedding, ground water barriers, backfilling, compacting and finish grading.

5.1.2 Jobsite management

- a. Contractor shall contact the District, all utilities and affected parties at least 48 hours (exclusive of holidays and weekends) before working in areas adjacent to underground utilities.
- b. Contractor shall verify vertical and horizontal locations of all existing utilities before installation of District facilities.
- c. Site cleanup shall be executed during the progress of the work, and at the completion of the work. All exterior paved surfaces shall be broom cleaned and left in good repair.
- d. Containers shall be provided for the collection of wasted material and debris. Containers shall be stored out of the right-of-way. To maintain an orderly site, waste material and debris shall be removed periodically.
- e. Construction materials, equipment, waste containers, construction buildings, parking, etc., shall only be allowed within the limits of the construction easement. Any off-site storage of construction material, equipment, waste containers, construction buildings, parking, etc. shall be allowed only after the Contractor has obtained the written permission of the property owner.
- f. Upon completion of construction, the job site shall be restored to its original condition or better. All topsoil shall be restored to its original quality. Any areas which are stripped of vegetation before or during construction shall be reseeded.
- g. Pavement and subgrade shall be restored to the specifications of the entity having jurisdiction: the City of Fort Collins, City of Loveland, Town of Timnath, Town of Windsor or Larimer County.

5.1.3 Quality Assurance

- a. Soil compaction tests shall be performed in accordance with:
 - **ASTM D698** --- Standard Test Methods for Laboratory Compaction Characteristics of Soil Using Standard Effort (12,400 ft-lbf/ft³ (600 kN-m/m³)).

- **ASTM D6938** --- Standard Test Methods for In-Place Density and Water Content of Soil and Soil-Aggregate by Nuclear Methods (Shallow Depth).
- **ASTM D1556** --- Standard Test Method for Density and Unit Weight of Soil In Place by the Sand-Cone Method.
- **ASTM D1557** --- Standard Test Methods for Laboratory Compaction Characteristics of Soil using Modified Effort (56,000 ft-lbf/ft³ (2,700 kN-m/m³)).
- **ASTM D4253** --- Standard Test Methods for Maximum Index Density and Unit Weight of Soils Using a Vibratory Table.
- **ASTM D4254** --- Standard Test Methods for Minimum Index Density and Unit Weight of Soils and Calculation of Relative Density.

5.1.4 Construction Staking

- a. All Wastewater Systems shall be Construction Staked by or under the direct supervision of a Professional Land Surveyor licensed in the State of Colorado.
- b. Survey notes and other Construction Staking notes shall be entered into a bound, water-resistant data book. All survey data/books shall be available for review upon request by the District.
- c. Adequate Construction Staking shall be provided to establish acceptable horizontal and vertical control. In cases where conflicts may exist or additional Construction Staking may assist the District in determining compliance with final Drawings, the Contractor shall supply such staking at no cost to the District.
- d. Cut/offset Construction Stakes shall be placed at a location whereby the stakes are not destroyed during trenching and backfill operations and can be easily read/identified.
- e. The only acceptable method for verifying and confirming horizontal and vertical layout during actual installation of Wastewater Systems shall be by certified laser device or cut/offset Construction Stakes.

5.1.5 Drainage and Groundwater

- a. Contractor shall obtain all necessary permits before starting dewatering operations and shall keep these permits available for review by the District.
- b. Water that is encountered in the trench shall be removed to the extent necessary to provide firm subgrade, to permit connections to be made in dry conditions, and prevent the entrance of water into the pipeline.
- c. Surface runoff shall be diverted as necessary to keep excavations and trenches free from water during construction.

- d. The excavation or trench shall be kept free from water until the structure, or pipe, to be installed therein, is completed to the extent that no damage from hydrostatic pressure, flotation, or other cause will result.
- e. Water shall be prevented from entering any sewer pipe which is already in service and has been accepted by the District.
- f. The pipe under construction shall not be used for dewatering without the written approval of the District.

5.1.6 Sequencing

- a. No more than 300 linear feet of open trench excavation and pipe installation will be allowed at any time. This distance may be amended, with the District's approval, based upon job conditions.
- b. Initial trench backfill shall be performed within 50 linear feet of pipeline installation. This distance may be amended, with the District's approval, based upon job conditions.
- c. Backfill shall be completed, at the end of each day, to the extent that no damage from hydrostatic pressure, flotation, or other cause will result.
- d. Where excavation is a hazard to automotive or pedestrian traffic, the amount of open trench and the time duration of that opening is to be coordinated with the appropriate authority's discretion.
- e. Contractor shall be solely responsible for construction site safety.
- f. All excavations shall be properly barricaded, signed, and protected to prevent unauthorized access.

5.1.7 Underground Obstructions

- a. The Design Engineer and/or Contractor shall field verify any Record Drawing information obtained from the District, prior to start of any Work.
- b. Contractor shall notify each utility owner and request utilities to be field located by surface reference.
- c. The request for the location of utilities shall be made a minimum of 48 hours before trenching or excavation (exclusive of holidays and weekends).
- d. The Contractor shall expose and verify the size, location, and elevation of all underground utilities and other obstructions, sufficiently in advance of construction to permit changes to be made to the Construction Drawings, and to secure approval of those changes.
- e. In the event there is a conflict, the Contractor shall notify the District and the affected utility company.
- f. In the event there is a conflict, the proposed work may be modified, at the District's discretion and with the Design Engineer's concurrence.

- g. Existing improvements, adjacent property, utilities, trees, and plants that are not to be removed shall be protected from injury or damage resulting from the Contractor's operations.
- h. If the Contractor removes any underground obstructions, the obstructions shall be replaced or repaired as directed and first approved by the affected agency or owner.

5.1.8 Maintenance and Correction

- a. Trench settlement, including any related damage to pavement, curb and gutter, sidewalks or other structures, which occurs during the warranty period, shall be the responsibility of the Contractor.
- b. The Developer/Contractor shall be responsible for obtaining all necessary permits to affect repairs within the right-of-way or Easement.
- c. The Developer/Contractor shall coordinate all repairs with the appropriate agencies, including the District.
- d. Contractor shall warrant work for a period of two years after a Substantial Completion Status has been granted by the District.

5.2 Materials

5.2.1 Stabilization Material

- a. If the existing soil in the trench bottom is judged to be unsuitable by the Contractor or the District, a minimum of the top 6-inches of the pipe subgrade shall be removed and replaced with a stabilization material.
- b. Stabilization material is crusher-run rock, conforming to ASTM D448, or CDOT Table 703-2 No. 357, or an approved substitute.

Stabilization Material	
Size	Percent Passing
2"	95-100
1"	35-70
1/2"	10-30
#4	0-5

- c. In all situations where stabilization material is required, geotextile fabric shall be placed in between stabilization material, and pipe bedding. Geotextile fabric shall meet the requirements of CDOT 712.08 (AASHTO M-288) Class A fabric.
 - Grab strength: 180 lbs. (ASTM D4632)

- Seam strength: 160 lbs. (ASTM D4632)
- Puncture strength: 80 lbs. (ASTM D4833)
- Trapezoid tear: 50 lbs. (ASTM D4533)
- Apparent opening size (AOS): less than 0.297 mm. (greater than No. 50 sieve) (ASTM D4751)
- Permeability, cm/s: $k_{\text{fabric}} > k_{\text{soil}}$ for all classes (ASTM D4491)
- Ultraviolet degradation at 500 hours: 50% strength retained for all classes. (ASTM D4355)

5.2.2 Pipe Zone

- a. The bedding area shall extend from 4 inches (or 1/4 O.D., whichever greater) below the bottom of the pipe to 12 inches above the top of the pipe, herein known as the “Pipe Zone”.
- b. Bedding shall not compromise the integrity of poly-wrap or other material/covering used to protect the pipe system from corrosion or other conditions.
- c. Reference Standard Drawing SS-10.

5.2.3 Bedding Materials

- a. Bedding for Sewer Mains shall be granular material, uniformly graded, crushed material, conforming to the following:

Sewer Main Bedding CDOT Table 703-2 No. 67	
Size	Percent Passing
1"	100
3/4"	90-100
3/8"	20-55
#4	0-10
#8	0-5

- b. The Service Line should be bedded with the same material as the Sewer Main or may be bedded with the following:

Service Line Bedding CDOT Table 703-2 No. 8 (aka squeegee)	
Size	Percent Passing
1/2"	100
3/8"	85-100
#4	10-30
#8	0-10
#16	0-5

5.2.4 Groundwater Barriers

- a. Clay ground water barriers shall meet the following soil classifications:
- CH - inorganic clays of high plasticity, fat clays.
 - SC - clayey sands, sand-clay mixtures.
 - CL - inorganic clays of low to medium plasticity, gravelly clays, sandy clays, silty clays, clean clays.
- b. Concrete shall not be used unless specifically approved by the District.

5.2.5 Trench Backfill Material

- a. **Material:** Shall be placed from the top of the Pipe Zone to the ground surface or to the bottom of the pavement section, whichever is applicable.
- b. **Ordinary/Native Backfill:** Shall consist of material excavated from the site and be free from frozen matter, stumps, roots, brush, other organic matter, cinders or other corrosive material, debris, rocks or stones which are larger than 6 inches, in any dimension, or other materials considered unacceptable by the District.
- c. **Rocks or Stones:** Larger than 3 inches, in any dimension, shall not be placed within one foot of the pipe or within one foot of the top of the trench backfill.
- d. **Topsoil:** Shall not be used as backfill.
- e. **Imported Backfill:** Consists of material imported from off-site locations. Material shall be free of rock or gravel larger than 3 inches, and free of debris, waste, frozen materials, vegetation and other deleterious matter. Material shall meet the acceptable ASTM soil classification groups for locally available material. Topsoil shall not be used as fill.

- f. **Structure Backfill:** Material shall meet Class 1 Structure backfill, conforming to CDOT Standard Specifications Section 703.08

CL 1 Structure Backfill Material	
Size	Percent Passing
2"	100
#4	30-100
#50	10-60
#200	5-20

- g. **Flowable Fill:** Material shall be required for utility trenching in existing pavement or as directed by the District Inspector, and shall meet the requirements from CDOT Section 206 – Structure Backfill (Flow-Fill), Standard Specifications for Road and Bridge Construction.

5.2.6 Surface Restoration

- a. Surface restoration including pavement or seed mixes shall meet the standards of the entity in which construction occurs: City of Fort Collins, City of Loveland, Town of Windsor, Town of Timnath, Larimer County or a private entity owning the property.
- b. At a minimum, pavement and subgrade shall match existing pavement and subgrade.
- c. When trenching in areas that will be returned to vegetation, topsoil shall be separately excavated, stockpiled and returned to the topsoil zone.

5.3 Construction

5.3.1 Trenching

- a. Trenches shall be excavated by open cut methods, except where boring or tunneling is shown on Final Drawings, or as otherwise approved by the District.
- b. Trench width shall be maintained to within 3 inches of that specified on Standard Drawing SS-10.
- c. Care shall be used when operating mechanical equipment in locations where it may cause damage to trees, buildings, culverts or other existing property, utilities or structures above or below ground.
- d. Mechanical equipment shall be operated in such a manner that the bottom elevation of the trench can be maintained with uniform trench widths and vertical sidewalls of the bedding zone.

- e. Contractor shall follow the most current regulations concerning excavations set forth by OSHA; Title 29 CFR part 1926. Trench safety is the sole responsibility of the Contractor.
- f. Trench support is the sole responsibility of the Contractor. The District's presence in no way implies approval of trench support methods being utilized. The District Inspector reserves the right not to enter a trench which, in the District Inspector's opinion, may be unsafe.
- g. Trench alignment shall be sufficiently accurate to permit pipe to be aligned properly with minimum clearances between the pipe and sidewalls of the trench (or trench box) pursuant to Standard Drawing SS-10 of these Specifications.
- h. The trench sidewall shall not be undercut to obtain clearance.
- i. If the trench bottom is rock, the Contractor shall over-excavate the trench bottom and backfill and compact with suitable bedding material. The minimum over-excavation depth shall be 12 inches below the bottom of the pipe. The trench width through the extents of the rock excavation shall match the trench width above the top of rock elevation. The District may allow blasting within rock, with prior District approval and approval of all other relevant agencies. At a minimum, blasting will require an implemented plan to negate any fly rock.
- j. Over-excavation shall be backfilled and compacted with acceptable Bedding Material or Stabilization Material.

5.3.2 Pipe Zone and Subgrade

- a. Pipe Zone trench bottom shall be graded uniformly to provide clearance for each bell and barrel section of pipe.
- b. Loose material, water, and foreign objects shall be removed from the trench bottom.
- c. The Contractor shall provide a firm trench bottom, which is suitable for application of Pipe Zone bedding material.
- d. Wherever wet or unstable material is encountered in the bottom of the trench, said material shall be over-excavated to a depth of 6 inches, minimum.
- e. The over-excavation shall be backfilled with Stabilization Material and compacted as required by the District.
- f. Use geotextile where necessary around Stabilization Material and on the subgrade to stabilize subgrade and prevent fines from migrating into granular materials.
- g. The District may require the Contractor to provide an opinion from a Geotechnical Engineer if the District determines the conditions merit special investigation.

5.3.3 Stockpiling Excavated Materials

- a. Suitable material for backfilling shall be stockpiled in an orderly manner and stored away from the edge of the trench.
- b. Contractor shall dispose of unsuitable or excess excavated materials.
- c. Excavated material shall not be stockpiled against or over existing structures or appurtenances.
- d. Excavated materials shall not be stockpiled beyond, or in a manner not consistent with an approved erosion control plan.

5.3.4 Pipe Zone Bedding

- a. Reference Standard Drawing SS-10.
- b. Bedding material shall be distributed and graded to provide uniform and continuous support beneath the pipe, including services at all points between bell ends, or pipe joints.
- c. Pipe shall not be supported by the bells.
- d. A minimum of 4 inches of bedding shall be placed before installing pipe, including services.
- e. Bedding material shall not be dropped on unsupported pipe or pipe, which is supported only at the ends. Pipe shall be uniformly supported before continuing with bedding lifts.
- f. Bedding shall be consolidated under and around the pipe.
- g. Bedding material shall not be placed in a manner that could damage protective coating, poly wrap, or similar elements of the pipe system.
- h. To prevent lateral displacement, bedding material shall be deposited and compacted uniformly and simultaneously on each side of the pipe.
- i. Care shall be taken when installing pipe to prevent damage to protective coatings, poly wrap, or similar elements of the pipe system. Workers shall not walk on coated or protected pipe.
- j. Any pipe coatings, poly wrap, or other surface damage shall be repaired according to manufacturer/supplier recommendations and in a manner acceptable to the District before backfilling.

5.3.5 Groundwater Barriers

- a. Groundwater barriers shall be constructed in a manner that impedes passage of water through the entire portions of the trench pipe zone and backfill material.

- b. Ground water barriers shall be no more than four hundred (400) feet apart. Ground water barriers shall be placed generally near the up-gradient side of the manhole unless otherwise directed by the District.
- c. If the ground water barrier is near an irrigation ditch, pond, stream, or other waterway, the barrier shall extend to a point one (1) foot above the 100-year water level.
- d. Reference Standard Drawing SS-11.

5.3.6 Backfilling and Compaction

- a. At a minimum, compaction shall meet the requirements of the applicable City, Town or County.
- b. All trench backfill shall be mechanically compacted, including services.
- c. No compaction shall be done by use of a drop hammer compactor.
- d. Compaction shall not be performed by jetting or water settling.
- e. Backfill of pipe and appurtenances and around vaults and valve boxes shall be compacted in a manner which can produce the required results.
- f. Backfill material shall be deposited in uniform horizontal layers which shall not exceed depth necessary to meet density requirement. Smaller compaction equipment will require shorter lifts.
- g. Equipment or backfilling methods which damage the pipe, pipe coatings, poly wrap, or other elements of the pipe system shall not be utilized.
- h. Topsoil shall be replaced to the depth of stripping over all areas, which are to be reseeded or otherwise restored.

5.3.7 Manholes

- a. Before completion of backfilling, manholes shall be raised to subgrade. Manhole adjustment shims plus the frame shall not exceed 16 inches and the depth from surface to first manhole step shall not exceed 28 inches.
- b. Manhole rings shall be straight and properly aligned.
- c. Construction materials and foreign matter shall be removed from the interior of manholes. Care shall be taken to ensure foreign matter does not enter the sewer collection system.
- d. Asphalt or oil which covers a manhole lid shall be removed and the lid or cover replaced so access to the structure is available.

5.3.8 Field Quality Control

- a. All tests shall be the responsibility of the Developer/Contractor and shall reflect results in accordance with these Specifications.

5.3.9 Field Moisture and Density Testing Control

- a. Field tests will be conducted to determine compliance of moisture/density requirements in accordance with ASTM D6938. Moisture/density testing may also be performed according to ASTM D1556. Where inconsistent or conflicting test results are obtained other methods of determining in place moisture and density may be required.
- b. Moisture/density tests are the responsibility of the Contractor and shall be performed by an independent geotechnical consultant.
- c. The District may elect to perform separate moisture and density tests at any time.
- d. The method of testing compacted material shall be determined by the geotechnical consultant or the District. The validity of the results shall be the responsibility of the geotechnical consultant.
- e. Test results shall be submitted to the District by the Contractor or the geotechnical consultant within 24 hours of the test, or by the end of the next working day. Copies of the field work sheets are acceptable.
- f. Results of all moisture and density tests shall be submitted to the District and approved by the District before acceptance of Wastewater Systems. Approved test results shall be available on the job site.
- g. Moisture/density test shall be performed at a depth not more than 2 feet above the top of the pipe bedding and in 2-foot increments up to the final grade. Test locations shall be staggered within each lift so that successive lifts are not tested in the same location.
- h. Moisture/density test shall be performed at a minimum of 200 lineal feet, as measured along the length of the pipe, or as determined by the District. Testing may be requested at an increased frequency and/or at specific locations.
- i. Moisture/density tests shall be performed on trench backfill, a minimum of one time for each Service Line installed. Certain cases may require additional tests, as required by the District and the entity having jurisdiction over pavements.
- j. Moisture and density tests in the vicinity of manholes shall be performed at a maximum of one (1) foot away from the manhole section. If nuclear test methods provide uncertain or inconsistent results due to the proximity of the structure, sand cone tests or other approved methods will be used.
 - A test shall be made in all four directions from each manhole and at different elevations.
 - A minimum of one (1) test shall be performed for every two (2) feet of backfill material.
 - Failed test areas shall be recompacted and retested at the Contractor's expense.

- k. Compaction and moisture content shall be to the following minimum standards unless recommended otherwise by the geotechnical engineer and approved in writing by the District. (Reference ASTM D698 or AASHTO T99, unless otherwise indicated).
- Ground water barrier material: 95% of maximum standard Proctor dry density (ASTM D698) between optimum moisture content and three percent over optimum moisture content.
 - Pipe Zone bedding: 85% of relative density (ASTM D4253 & D4254)
 - Trench backfill: 95% of standard Proctor maximum dry density (ASTM D698).
- l. In instances where the distance from the top of the pipe to the finished surface of the ground is less than four (4) feet, special design shall be required which may include a concrete cap.
- m. Moisture content.
- The acceptable range of moisture content for compacted trench backfill will be within two percent (+/-) of the optimum moisture content determined by the standard Proctor test (ASTM D698) unless recommended otherwise by the geotechnical engineer and approved in writing by the District.
 - Variances may be requested by submitting a report and recommendation from a private geotechnical consultant accompanied with a letter that specifically identifies the variance. Submittals should be directed to the District Engineer.
 - If water is added to the material, the material shall be harrowed, disked, bladed, or otherwise worked to ensure a uniform moisture condition.

Chapter 6 – Materials and Installation

6.1 General

6.1.1 Scope

This chapter addresses the installation of Wastewater Systems, and includes the acceptable products, materials, and construction practices which may be used in the installation of the Wastewater System. There are separate requirements for lift stations and force mains that may be obtained from the District.

6.1.2 Execution

- a. Contractor shall furnish all materials, equipment, labor, and incidentals necessary for the execution, testing, and completion of the work. All materials and equipment shall be of good quality and new, except as otherwise approved by the District.
 - b. When requested by the District, the Contractor shall furnish satisfactory evidence (including manufacturer's certification) as to the kind and quality of materials and equipment, and their compliance with these specifications. The District shall test any manufacturer's material it deems necessary. It is the Contractor's responsibility to ensure the manufacturer's materials supplied meet these Specifications.
 - c. All materials and equipment shall be installed and used in accordance with the instructions of the applicable manufacturer, fabricator, supplier or distributor, except as otherwise provided in these Specifications. The specification of materials and equipment shall be understood to be representative of a quality of performance, operation and construction acceptable to the District.
 - d. The District will evaluate all written requests for product substitution. Such requests shall include detailed product literature and a description of benefits which might be achieved by this substitution.
 - e. In approving materials or equipment for installation, the District assumes no responsibility for injury or claims resulting from failure of the materials or equipment to comply with the applicable National, State, and local safety codes or requirements, or the safety requirements of a recognized agency, or failure due to faulty design concepts, or defective workmanship.
- a. Refer to the Approved Materials List on the District website.

6.2 Materials: Pipe, Related Fittings and Appurtenances

6.2.1 Pipe

- a. Wastewater pipe and fittings shall be made from PVC conforming to ASTM D1784.

- b. Pipe shall be furnished with fittings, specials and other accessories.
- c. 4 inch through 15 inch plastic gravity wastewater pipe and all fittings shall be manufactured in accordance with ASTM D3034. The dimension ratio (DR) shall be 35 (DR35) which has a Pipe Stiffness (PS) of 46 psi (PS46). Sewer Mains 20 ft and deeper shall comply with DR 26 with a PS of 115 psi (PS115).
- d. 18 inch through 48 inch plastic gravity wastewater pipe and all fittings shall be manufactured in accordance with ASTM F679 and the pipe stiffness (PS) shall be 46 psi (PS46). Sewer Mains 20 ft and deeper shall comply with ASTM F679, with a PS of 115 psi (PS115).
- e. All joints shall be of the push-on bell and spigot type and shall be manufactured in accordance with ASTM D3212.
- f. All gaskets shall be manufactured in accordance with ASTM F477.
- g. All bells shall be formed integrally with the pipe and shall contain a factory installed elastomeric gasket, which is positively retained.
- h. Lubricant shall be that which is specified by the pipe manufacturer.

6.2.2 Service Connections

- a. The Contractor shall place wyes, stubs and cleanout assemblies where required by the Final Construction Plans.
- b. Watertight plugs or caps capable of withstanding test pressures shall be installed in each branch pipe or stub.
- c. Service connections shall be no closer than three feet from manholes or other service connections.

6.2.3 Marker Posts

- a. Manholes in Unpaved Areas: Marker posts shall be Carsonite CRM-375 with reflective labels or approved equal.
- b. Service Line Stubs: Marker posts shall be nominal 4X4 posts painted green.

6.2.4 Tracer Wire

- a. Tracer wire shall consist of copper-clad steel 12-AWG high strength with minimum 450 lb. break load, minimum 30 mil green HDPE insulation, rated for direct burial.

6.2.5 Marker Tape

- a. Marker tape shall be green, 6 inches wide, detectable by utility locating equipment and placed continuously in trench backfill directly over Sewer Mains and Service Lines at a depth between 12 inches and 24 inches below finished grade.

6.3 Materials: Manholes

6.3.1 Manhole Specifications

- b. Precast Concrete Manholes, reference Chapter 9, Precast Concrete.
- c. Cast-in-Place Manhole Bases, reference Chapter 8, Cast-in-Place Concrete.
- d. Manholes shall be furnished with all accessories, including steps, base, cone section and ring and cover.

6.3.2 **Grout** shall be pre-mixed, non-metallic, non-aggregate, and non-shrink using the following ratio of ingredients:

- a. One part Portland Cement; conforming to ASTM C150, Type I, I1, II, IIA,
- b. One part sand; conforming to ASTM C144,
- c. One part shrinkage correcting aggregate.

6.3.3 **Ring and Cover**

- a. All rings and covers shall be cast iron material with a minimum of an H-20 load rating.
- b. Rings for built-up construction shall be 8 inches in height.
- c. Shorter rings may be acceptable for street overlays or repaving, with written approval of the District Engineer.

6.3.4 **Steps**

- a. All steps, in manholes, shall be made of Copolymer Polypropylene Plastic conforming to ASTM C478 and ASTM C497.
- b. All steps shall be spaced 12-inches apart on center and in uniform alignment.
- c. The maximum distance from the cover of the manhole to the first step shall be 28 inches.
- d. The maximum distance from the bench of the manhole to the lowest step shall be 18 inches.

6.3.5 **Infiltration-Proofing**

- a. Manholes shall not be located in areas subject to flooding from surface runoff.
- b. Manholes shall not be located where ponding or storm detention may occur.
- c. If a manhole is located within the 100-year flood plain, the manhole shall be equipped with an inflow protector. See Appendix D for approved models.

6.3.6 Rubberized Gaskets Between Concrete Sections

- a. All manhole sections shall have two (2) Gaskets per section joint (inside and outside).
- b. Gaskets shall conform to AASHTO M198 and Federal Specification SS- S-00210(210A)
- c. Gaskets must be pliable at the time of installation at a temperature of 10oF. and above without being heated.
- d. Primer is required on all joints. Primer shall be supplied by the gasket manufacturer.
- e. For existing pipe penetrations: A flexible pipe-to-manhole connection is required.

6.3.7 Pipe Penetration Gaskets

- a. All stainless steel hardware is required.

6.3.8 Lining

- b. The District may require manholes to be coated with a special lining in areas subject to high corrosion.
- c. Lining shall be applied at a minimum of 60 mils and in accordance with manufacturer's recommendations.

6.3.9 Coating

- a. All manholes shall be damp-proofed. An exemption from damp-proofing may be granted by the District if the Design Engineer can reasonably demonstrate that soil at the manhole location will never become saturated.
- b. Dampproof coatings shall be factory applied.

6.3.10 Wrap

- a. Every manhole joint shall be taped on the outside of the manhole.
- b. Where groundwater may be encountered, the entire manhole shall be wrapped.

6.3.11 Grease, Sand & Oil Interceptors

- a. District requirements for grease, sand and oil separators are described in a separate document available on the District website.

6.4 Construction and Installation

6.4.1 Product Delivery, Storage and Handling

- a. Do not drop materials or equipment. Use slings, pipe tongs, skids or other controlled methods for handling materials and equipment.
- b. Care must be taken to prevent damage to materials and equipment by impact, bending, compression, abrasion or other deleterious handling.
- c. Damaged materials and equipment shall not be installed.
- d. Lubricant shall not be stored or handled in a manner that will cause contamination.
- e. Rubber gaskets shall be stored in a location which protects them from deterioration.
- f. Neatly store materials and equipment in accordance with the manufacturer's specifications.
- g. Pipe shall be stored in accordance with the manufacturer's specifications and on a surface that will provide an even support for the pipe barrel. Do not store in a manner that supports the pipe by the bell.
- h. Pipe, fittings and joints shall be kept free from dirt, oil and grease.
- i. Pipe which has a longitudinal deflection (bend) greater than 1/8 inch per foot shall not be used.
- j. Pipe which exhibits any signs of ultraviolet degradation shall not be used.

6.4.2 Job Conditions

- a. Foreign material, including trench water, shall not be permitted in the pipe.
- b. The wastewater pipe being installed shall not be used to dewater the trench.
- c. Water shall be prevented from entering the wastewater pipe already in service or pipe previously accepted by the District.
- d. Debris, tools, clothing, or other material shall not be permitted in the pipe.
- e. In order to prevent anything from entering the pipe, the open ends of the pipe shall be plugged with a restrained, watertight plug when pipe laying is not in progress.
- f. Unattended open pipes connected to the District Wastewater System shall be the basis for the District to levy fines.
- g. If unpermitted groundwater or stormwater enters the District Wastewater System, the Developer shall compensate the District for:

- Fines.
 - Damages to District infrastructure.
 - Costs for District field personnel and equipment to respond, including emergency and overtime costs.
 - Costs associated with treatment of excess and/or complicated wastewater.
- h. Effective measures shall be used to prevent uplifting or floating of the pipeline prior to completion of the backfilling operations.
- i. Pipe shall not be installed under the following conditions:
- When trench water is entering the pipe.
 - When weather conditions are unsuitable.
 - Temperature is less than 10°F. Written approval is required from the District when the temperature is 10°F or less.
 - Snowing heavily.
 - Raining heavily.
 - High winds.
 - When the trench bottom is unstable.
- j. Do not use damaged materials or equipment for installation in the system.

6.4.3 Inspection

- a. Pipe barrel, joints and fittings shall be free of dirt or other foreign objects prior to installation.
- b. Pipe, joints and fittings with cracks, dents, abrasions or other flaws shall be rejected.
- c. Pipe, joints and fittings with damaged linings or coatings shall be rejected.
- d. Manholes with cracks or other flaws shall be rejected.
- e. No wastewater pipe may be covered or backfilled until inspection of pipe and bedding has been made.

6.4.4 Cutting the Pipe

- a. The pipe shall be cut smooth, straight, and at right angles to the pipe axis, with saws or pipe cutters designed specifically for the material.
- b. The cut end of the pipe shall be beveled in accordance with the manufacturer's recommendations.

- c. Burrs shall be removed and all dust shall be wiped off of the jointing surface.

6.4.5 Connections

- a. The location and elevation of the existing pipes and manhole inverts shall be verified before construction.
- b. Connections to existing pipes shall be made with an approved coupling device.

6.4.6 Joints

- a. Dirt, oil, grit, and other foreign matter shall be removed from the inside of the bell and outside of the spigot.
- b. A thin film of lubricant shall be applied to the inside of the gasket and the spigot end of the pipe, per the manufacturer's recommendations.
- c. Preparatory to making pipe joints, all surfaces of the joint shall be clean and dry.
- d. The lubricated joint shall be kept clean.
- e. The pipe shall have a depth mark prior to the assembly to ensure that the spigot end is inserted to the proper depth of the joint.
- f. The pipe shall be joined to the tolerances recommended by the manufacturer.
- g. The pipe shall be set in position and checked for line and grade using care to keep the joint absolutely free of dirt.
- h. When final grade is achieved, the joint shall be carefully pushed together until the assembly mark on the spigot is aligned with the end of the pipe using approved methods of leverage. Stabbing of the pipe is not allowed.
- i. Care shall be taken so that the bell end of the pipe will not be deflected.
- j. The seating of the gasket shall be checked around the entire circumference of the pipe by visual and feeler gauge inspection.
- k. Previously completed joints shall not be disturbed during the jointing operation.
- l. Joints shall be watertight and free from leaks.
- m. After the initial acceptance of the wastewater system, the Contractor shall be responsible for the repair of any leak, high spots or low spots resulting from improper workmanship or materials, discovered within the warranty period.

6.4.7 Pipe Installation

- a. Pipe centerline shall not deviate from the horizontal alignment in the Final Construction Plans by more than 0.15 feet. To ensure proper installation, pipe shall be installed using a Pipe Laser to determine alignment and grade, and by no other means.

- b. Pipe invert, for the entire run/reach of pipe between manholes, shall not deviate from the Final Construction Plans by more than 0.04 feet or create sags greater than specified in Section 7.8 of these Specifications.
- c. Pipe shall be laid and maintained at required lines and grades as specified in the Final Construction Plans.
- d. Pipe installation shall be constructed continuously on an upgrade from an existing structure; except when approved by the District Engineer.
- e. Pipe shall be installed so that the bells are pointing uphill.
- f. Grade/pipe invert changes shall not be allowed within any run/reach between manholes.
- g. Bedding material shall not be dropped onto unsupported pipe which has been set to alignment and grade.
- h. The pipe shall be secured in place with the specified granular bedding material consolidated under and around the pipe.
- i. The Contractor shall prevent the opening of joints during bedding and backfilling operations.
- j. The joint shall be completed and the pipe adjusted to the correct line and grade as each length of pipe is placed in the trench.
- k. The pipe shall be secured in place by careful installation of bedding material.
- l. Sewer Mains which cross waterways shall be installed as indicated on the Final Construction Drawings and as required by the District.
- m. Sewer Mains shall cross under water lines by at least 18 inches. Special approval is required for any Sewer Main or Service Line to cross over a water line. Approval must be received from the District Engineer, and from the owner of the water line, and that approval is based on a proposed design from the Design Engineer.
- n. Horizontal alignment shall remain uniform between consecutive manholes as shown on the Final Construction Drawings.
- o. Vertical alignment shall remain uniform between manholes, with no deviation from the grade specified on the Final Construction Drawings.

6.4.8 Casing and Carrier Pipe

- a. Service Lines and Sewer Mains shall pass beneath water and stormwater lines. Using a casing to pass above any water and stormwater line will only be allowed with special permission from the District and the owner of the water or stormwater line. A site-specific casing design must be submitted to the District and the owner(s) of the water or stormwater line for review. Submission of a design does not necessarily imply acceptance of the design.

- b. Projects requiring boring, jacking and other pipe installation methods besides trenching will be project-specifically designed and submitted to the District for review and approval. Submission of a design does not necessarily imply acceptance of the design. A geotechnical investigation and report will likely be required with the site-specific design for these construction methods.

6.4.9 Manhole Construction

- a. Manholes shall be installed at the location and to the elevation shown on the Final Construction Drawings, or as approved by the District Engineer to accommodate field conditions.
- b. Measurements of the actual location and elevation of Sewer Main inverts shall be made for recording in the Record Drawings by the Design Engineer.
- c. Standard manholes shall be installed in accordance with Standard Drawing SS-1.
- d. Flat-top manholes shall be installed in accordance with Standard Drawing SS-1
- e. Flat-top manholes are required whenever the distance between the finished road surface and a manhole barrel section does not allow room for a cone section.
- f. Access holes for flat-top manholes shall be offset from center.
- g. Manholes shall be set plumb.
- h. Precast concrete adjustment rings shall be used to bring the ring and cover to grade. See Standard Drawing SS-1.
- i. The total height from the top of a manhole cone section, or flat-top manhole, to the finish street grade, shall not exceed 16 inches.
- j. The adjustment rings shall be flush with the inside of the manhole.
- k. Joint surfaces shall be kept clean, dry, and warm during installation.
- l. Rubberized gasket material shall be used for joining the precast concrete section to the manhole base, joining the precast manhole sections, joining the adjustment rings, and joining the frame to the adjustment rings.
- m. Rubberized gaskets shall be installed as follows:
 - Clean the joint surfaces before priming.
 - Apply primer on all joint surfaces in contact with gasket material.
 - Place two gaskets per joint except as noted below.
 - One gasket may be used for joining the adjustment rings.

- One gasket may be used for joining the frame to the adjustment ring.
 - Overlap the gasket material, 6 inches.
 - Leave protective paper on the outside of gaskets during application and remove when the joint is ready to be joined.
 - Excess gasket shall be trimmed flush to the interior wall.
- n. Lifting holes and other imperfections shall be filled with an approved non-shrink grout, to provide a smooth finished appearance.
- o. All joints shall be taped on the exterior.
- p. For buried manholes, wrap the ring and cover with minimum 10-mil plastic sheeting.

6.4.10 Drop Manholes

- a. Drop manholes are discouraged but may be allowed on a case-by-case basis. Before approval of a drop manhole, the Design Engineer must provide alternatives for review and consideration by the District Engineer. Drop manholes will only be considered when the drop is two feet or greater and no other alternative is practical.
- b. If a drop manhole is allowed by the District Engineer, only an outside drop manhole will be permitted.
- c. If approved, drop manholes shall be designed and constructed as shown in Standard Drawing SS-6.

6.4.11 Connections to Existing Manholes

- a. Connections to existing manholes shall be made by core-drilling. Jack-hammering is not allowed.
- b. Manhole core shall be sealed with a gasket.
- c. Connections to existing manholes shall not be made within 12 inches of another connection.
- d. Service Lines shall not be connected to manholes unless specifically approved by the District Engineer.
- e. See Standard Drawing SS-2.

6.4.12 Service Lines

- a. Service Lines shall be installed at the locations designated on the Final Construction Drawings.
- b. Reference Standard Drawings SS-7 and SS-8.

- c. Service Line taps on existing Sewer Mains shall be installed using approved materials. A District Inspector must observe tapping and observe the tap connection and Service Line before burial. Particular attention will be paid to bedding supporting the tap assembly.
- d. Service Lines shall be extended at a constant grade to a point behind the utility easement.
- e. The end of Service Lines shall be plugged with an airtight plug or cap.
- f. The end of all Service Line stubs shall be marked with a 4" x 4" wooden marker, painted green. All wooden markers shall extend from the end of the service to a point four (4) feet above the ground surface. Wooden markers shall be installed per Standard Drawing SS-7.

6.4.13 Tracer Wire

- a. Tracer wire shall be installed with all Sewer Mains and Service Lines regardless of material type.
- b. Tracer wire installation shall be performed in such a manner that allows proper access for connection of line tracing equipment, proper locating of wire without loss or deterioration of low frequency (512 Hz) signal, and without distortion of signal caused by more than one wire being installed in close proximity to one another.
- c. Any damage occurring during installation of the tracer wire must be immediately repaired by removing the damaged wire and installing a new section of wire with approved connectors. Taping and/or spray coating shall not be allowed.
- d. A tracer wire shall be attached to the top of each pipe with approved tape, at an interval no less than every 4 feet.
- e. For Sewer Mains, tracer wire shall terminate by attachment to a ground rod near a manhole at one end of a Sewer Main run and terminate at the other end of the same run by extending the wire into the top of the manhole as shown on Standard Drawing SS-13.
- f. For Service Lines, tracer wire shall terminate at a ground rod at the Service Line tap and extend to the end of the stub or to the building served, as shown on Standard Drawing SS-14.
- g. Splices are not allowed unless approved connectors are utilized.

6.4.14 Abandonment of Manholes

- a. Remove the ring and cover, grade rings, and cone section.
- b. Set a plug in each inlet and outlet pipe, two feet outside of the manhole.
- c. Seal each inlet and outlet pipe with concrete from inside the manhole to the plug and fill the manhole sections with flow-fill.

6.4.15 Abandonment of Sewer Mains

- a. Sewer Mains shall be removed and not abandoned in place. When allowed by the District Engineer, Sewer Mains shall be plugged as follows:
 - Place a watertight plug in the end of pipe to be abandoned.
 - Pour a concrete seal on the end of the pipe.
- b. The District may require flowfill or flashfill for larger Sewer Mains on a case by case basis depending on pipe location , pipe material and surface conditions.
- c. See Standard Drawing SS-12.

6.4.16 Abandonment of Service Lines

- a. Remove a section of the Service Line from the wye at the Sewer Main.
- b. Place a watertight plug in the Service Line wye.
- c. A concrete seal may be required over the plug on VCP Sewer Mains.
- d. Service Lines are not owned by the District, and the disposition of the remainder of the Service Line is at the discretion of the owner of the property formerly served by the Service Line.
- e. See Standard Drawing SS-12.
- f. CIPP point repair may be used at the discretion of the District Engineer. CIPP shall be performed by a contractor acceptable to the District. Pre-lining and post-lining digital videos shall be submitted to the District before acceptance.

6.4.17 Abandonment of wastewater services inside Manholes.

- a. Place a watertight plug at least 6” into the end of service to be abandoned.
- b. Grout inside the service, against the plug, to the outer edge of the manhole.
- c. Reform and repair invert or bench.

Chapter 7 - Testing Wastewater Systems

7.1 General

The Contractor shall perform and be financially responsible for all testing. The Contractor shall provide all equipment and personnel to perform the required tests. The District will not approve tests that were not observed by a District Inspector. The District Inspector shall inspect all Wastewater Systems installed pursuant to these Specifications. All work must be acceptable by the District before being placed in service.

7.2 Inspection Procedures

- 7.2.1 **Request:** The Contractor shall request inspections a minimum of two working days in advance.
- 7.2.2 **Access:** The authorized agents and their representatives of the District shall be provided safe access to the work, whenever it is in preparation or progress. The Contractor shall provide for such access and for inspections, including maintenance of temporary and permanent access. The Contractor shall not cover any portion of the Wastewater System until the District Inspector has inspected all workmanship and materials.
- 7.2.3 **Authorization:** The District Inspector shall be authorized to inspect and enforce these Specifications, as applicable. All materials, labor, tools and certain methods for installation shall be subject to inspection and approval by the District Inspector. If the District Inspector identifies a neglect, omission or disregard of these Specifications, such neglect, omission or disregard shall be remedied immediately, pursuant to the District Inspector's written instructions and these Specifications.
- 7.2.4 **Inspection Cost:** The Developer shall be responsible for the cost of inspection during non-standard inspection hours, re-tests, and excessive inspection. Standard inspection hours are 8:00 a.m. to 3:30 p.m., Monday through Friday, exclusive of holidays.
- 7.2.5 **Authorized Representative:** Before commencing work, Contractor shall designate, in writing, an authorized representative who shall have complete authority to represent the Contractor and shall be on the construction site at all times during work activities.
- 7.2.6 **Responsibility:** Inspection of workmanship and materials is intended to aid in the compliance with these Specifications. Such inspection, however, shall not relieve the Developer/Contractor from any obligations related to the requirements of these Specifications. Responsibility for the replacement of materials not in compliance with these Specifications shall rest entirely with the Developer/Contractor during installation and, as applicable, throughout the warranty period. Materials and equipment rejected by the District shall be identified and marked for removal.

- 7.2.7 **Safety:** The Developer/Contractor shall abide by all relevant local, state and federal safety requirements and programs. The District Inspector may warn the Contractor or Developer of unsafe conditions or situations and may stop work if an immediately dangerous condition is observed, but such warning, stop-work or the presence of the District Inspector does not imply any responsibility for site safety on the part of the District or District Inspector.

7.3 Material/Soil Testing

- 7.3.1 **Laboratory:** All geotechnical tests shall be made and certified by an approved testing laboratory and all test reports, analyses, and recommendations shall be prepared by an Engineer.
- 7.3.2 **Costs:** All costs pertaining to testing shall be the responsibility of the Developer/Contractor.
- 7.3.3 **Additional Tests:** Whenever, at the discretion of the District, additional tests or data are required beyond the minimum identified in these Specifications or on the Final Construction Drawings, the costs of such tests initially shall be the responsibility of the District. In the case where such tests or additional data show a failure to meet these Specifications or the Construction Drawings, the Developer/Contractor ultimately shall be responsible for such costs, along with all costs associated with necessary mitigation measures.

7.4 Pipe Testing

- 7.4.1 General
- a. Low-pressure air tests shall be conducted on all Sewer Mains and Service Lines.
 - b. Conduct tests in conformance with ASTM F1417 and these specifications.
 - c. A test section shall not be any longer than the length of pipe between adjacent manholes.
 - d. The test gauge shall indicate pressure increments no larger than 0.1 psi.
 - e. All pressures in this section assume no groundwater back pressure, if groundwater is present, increase test air pressures to compensate for the back pressure. Each foot of groundwater produces approximately 0.433 psi back pressure. For groundwater in excess of five feet (5') above the pipe crown, an infiltration test shall be used in lieu of air testing.
 - f. The Contractor shall provide all equipment and personnel to perform the required tests.
 - g. The District Inspector shall record times and pressure or vacuum readings during the test period.

7.4.2 Preparation for Tests

- a. Jet and clean the sewer line before testing to wet the pipe surfaces and produce more consistent results.
- b. Provide a relief valve on the pressuring equipment to avoid over-pressurizing and damaging an otherwise acceptable line. Set relief valve at 5.0 psi.
- c. Plug and brace all openings in the Sewer Main and the upper connections. Check all pipe plugs with a soap solution to detect any air leakage. If leaks are found, release the air pressure, eliminate the leaks and start the test procedures over again.

7.4.3 Test Procedure

- a. Add air until internal pressure is raised to approximately 4.0 psi. Maintain the air pressure between 3.5 psi and 4.5 psi until the air temperature in the pipe is stabilized with the pipe/ground temperature or a minimum of two minutes, whichever is longer.
- b. Disconnect the air supply and reduce the air pressure to 3.5 psi before starting the test.
- c. If the groundwater is higher than the top of the pipe, the test pressure shall be adjusted to account for the higher groundwater. The test pressure shall be increased by 0.433 psi per foot of ground water up to five (5) feet of groundwater. For groundwater over five (5) feet in depth, an infiltration test shall be conducted in place of the air test.
- d. Determine the time required for the air pressure drop from 3.5 psi to 2.5 psi or use the time from the table below:

- The time elapsed shall not be less than: $T=0.085 DK/Q$, where:

T = the shortest time allowed for air pressure to drop 1.0 psi

K = 0.000419 DL, but not less than 1.0

Q = leak rate of internal surface = 0.0015 CFM/SF

D = average inside diameter of pipe in inches

L = length of section in feet

- The following table depicts minimum test durations in minutes:seconds. Use the length greater than the length to be tested in the field.

Pipe Diameter (inches)	Pipe Length (feet)									
	50	100	150	200	250	300	350	400	450	500
8	07:33	07:33	07:33	07:33	07:33	07:36	08:52	10:08	11:24	12:40
10	09:27	09:27	09:27	09:27	09:54	11:52	13:51	15:50	17:48	19:47
12	11:20	11:20	11:20	11:24	14:15	17:06	19:57	22:48	25:39	28:30
15	14:10	14:10	14:10	17:48	22:16	26:43	31:10	35:37	40:04	44:31

- If Service Lines are included in the test, their length may be ignored for computing required test time.
 - Sections of pipe which fail the air test shall be repaired and the test must be repeated.
- If the District Inspector determines that reliable and uniform results are produced by the Contractor's construction techniques, the low air pressure air test may occur after initial backfill and compaction.
 - If, after visual inspection of the Sewer Main, the District Inspector finds there is a problem, the District may require alignment (lamp), infiltration, exfiltration and/or deflection tests.
 - A mandrel test may be required on 12 inch and Sewer Mains at the District's discretion.

7.5 Tracer Wire Testing

- 7.5.1 Tracer wires shall pass testing before Substantial Completion.
- 7.5.2 Testing shall be performed by a 3rd party testing company.
- 7.5.3 Testing shall demonstrate that the tracer wire can accurately locate the pipe.

7.6 Manhole Testing

- 7.6.1 All manholes shall be vacuum tested. Conduct tests in conformance with ASTM C1244 and these Specifications.
- 7.6.2 Manholes shall be tested before the ring and cover and grade adjustment rings are installed, and after backfill and compaction is complete.
- 7.6.3 Manholes with infiltration will not be tested until repairs have been made from outside of the manhole.

- 7.6.4 Service Lines entering manhole shall be tested with the manhole.
- 7.6.5 Pipes entering the manhole shall be plugged and braced.
- 7.6.6 A vacuum of 10 inches of mercury shall be drawn.
- 7.6.7 The vacuum pump shall be turned off and the time monitored.
- 7.6.8 The vacuum must not drop more than 1-inch of mercury for the duration of the time (in seconds) indicated in the following:
 - a. 4-foot diameter manholes: 1 minute
 - b. 5-foot diameter manholes: 1.5 minutes
 - c. 6-foot diameter manholes: 2 minutes
- 7.6.9 Repair and repeat testing of the failed manhole shall be performed at contractor's expense until the testing requirements are met.
- 7.6.10 Repair methods shall be approved by the District Inspector before proceeding.
- 7.6.11 There shall be no visible leaks, infiltration or moisture, other than condensation before or after testing or within the warranty period.

7.7 Video Recording Sewer Mains

- 7.7.1 All District wastewater lines shall be digitally video recorded. Each Service Line tap shall be recorded from the inside of the Sewer Main.
- 7.7.2 The recording of the line shall be submitted to the District. It is recommended that the recording be submitted and approved before the pavement is placed, so that any required repairs do not necessitate cutting and replacing pavement.
- 7.7.3 Each recording shall include the following information: District-supplied development name, street name, manhole number to manhole number, time, date and footage.
- 7.7.4 The recording shall be made using a color camera having sufficient light to show details including problem areas and joints. Sewer Mains shall be recorded from a self-propelled "crawler" that shall have a pan-and-tilt head capable of viewing Service Line taps.
- 7.7.5 Camera speed shall not exceed 3 feet per second and the camera shall be centered in the area above the liquid surface.
- 7.7.6 Sewer Mains and manholes shall be jetted clean before televising. After jetting, water shall be introduced in the upstream manhole until water exits from the downstream manhole before recording begins, so any sags may be observed.

- 7.7.7 The most downstream manhole in the Wastewater System to be cleaned and jetted shall have a mechanical plug placed in the outlet invert. All jetting and cleaning water and debris shall be vacuumed or otherwise cleaned from this downstream manhole before the plug is removed.
- 7.7.8 If issues or concerns are observed by the operator, then the camera shall be backed up and an extended view of the area will be recorded.
- 7.7.9 Recordings shall pause at each Service Line tap and the camera shall be rotated for a direct view of the tap.
- 7.7.10 Recordings will have time, date, and footage displayed.
- 7.7.11 The District Inspector will review recordings and if any area of the sewer line cannot be observed due to poor video quality, residual materials in the Sewer Main or other obstructions to viewing, the sewer line shall be jetted and digitally recorded again at the Developer's/Contractor's expense. This shall be repeated until Sewer Mains are cleaned to the satisfaction of the District Inspector.
- 7.7.12 At a minimum, a clean Sewer Main means that at least 90% of the interior of the pipe above the liquid surface shall be directly visible. This minimum requirement does not negate the need for recleaning if less than 10% of the pipe surface is not visible but is in a critical area at the discretion of the District Inspector.
- 7.7.13 If the video inspection of the Sewer Main identifies a problem, the District may require repair, alignment, infiltration, exfiltration and/or deflection tests, followed by a new video recording.

7.8 Sags

- 7.8.1 **Definition:** Sags, also known as bellies, are lengths of Sewer Main or Service Line that are vertically misaligned so that water may pond rather than flow freely.
- 7.8.2 **Acceptable Sags:** The percent of standing water at a sag will determine if the sag is acceptable.
 - a. Sags that make up 5% or less of the pipe area are approved.
 - b. Sags that are between 5% and 10% of the pipe area are at the discretion of the District Inspector.
 - c. Sags that are more than 10% of the pipe are unacceptable and shall be rejected.

7.8.3 **Visual Representation:** As a reference, the following diagram represents 5% and 10% of pipe area.

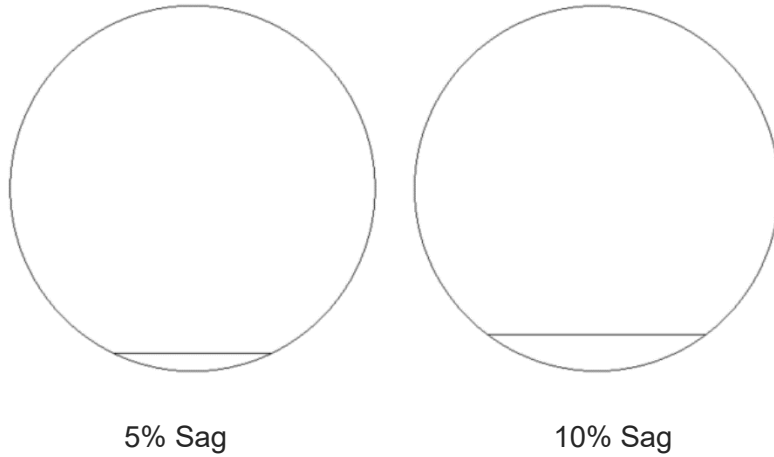

Chapter 8 – Cast-In-Place Concrete

8.1 Scope

This chapter covers cast-in-place concrete for cast-in-place manhole bases. The chapter will cover materials requirements, forms, reinforcing steel, finishing and curing, and other appurtenant work.

8.2 Materials

8.2.1 Cement

- a. Cement shall be Portland Cement conforming to ASTM C150.
- b. High early strength (12, 24, or 48 hour) concrete mixtures may be used with prior approval of the District. Acceptable type of early strength cement is Type III, or an approved equal.
- c. Cast-in-place concrete structure bases shall be Type V.
- d. Fly ash is NOT allowed for use.

8.2.2 Aggregates

- a. Fine aggregate shall be clean, sharp, natural sand conforming to ASTM C33.
- b. Course aggregate shall be clean, strong crushed gravel or stone conforming to ASTM C33. Gradation shall be as specified under concrete mixes.

8.2.3 Water

- a. Water shall conform to ASTM C94 and be free from silt, organic matter, alkali, salts, and other impurities.

8.2.4 Admixtures

- a. An air-entraining agent shall be used in concrete conforming to ASTM C260. Total air content shall be 5 to 8 percent.
- b. Accelerators shall conform to ASTM C494 and ACI 306.
- c. A water-reducing admixture may be used, if approved by the District.
 - Water-reducing admixture shall conform to ASTM C494, for Type A or Type D chemical admixture.
 - The water-reducing admixture shall not contain any calcium chloride.
 - The water-reducing admixture shall be compatible with the cement used.

- d. Any admixtures except air entraining agents, accelerators, and retarders must be approved by the District

8.2.5 Concrete Mix Design

- a. Cast-in-place concrete structure bases shall have a minimum of 6 sacks per cubic yard and shall develop a minimum compressive strength of 4000 psi after 28 days.
- b. Concrete shall have a maximum allowable water/cement ratio of 0.50 by weight.
- c. The water/cement ratio may be increased to 0.56, by weight, if a water-reducing agent is used.
- d. Slump: 4 inch maximum.
- e. Ready-mixed concrete shall be mixed and delivered in accordance with ASTM C94.

8.2.6 Concrete Reinforcement

- a. Deformed reinforcing bars shall conform to ASTM A996.
- b. Rebars shall be either Grade 40 or 60.
- c. Welded steel wire fabric shall conform to ASTM A185.

8.2.7 Forms

- a. Plywood shall be waterproof, resin-bonded, exterior type.
- b. Lumber shall be straight, uniform width and thickness, free from knots, offsets, hole and dents.
- c. Form oil shall be light colored paraffin oil, or other non-staining material.

8.3 Construction

8.3.1 Product Delivery, Storage and Handling

- a. Concrete:
 - All concrete must be delivered to the site from a ready-mix plant via revolving-drum truck.
 - The maximum elapsed time from the time water is added to the mix until the concrete is in place shall not exceed 1.5 hours when concrete is transported in revolving-drum truck bodies.

b. Reinforcing Steel:

- Carefully handle and store on supports to prevent the steel from contacting the ground.
- Remove mud, oil, loose rust or mill scale and other foreign materials before placing concrete.
- Rust or mill scale which is "tight" will be permissible without cleaning or brushing, provided weights, dimensions, cross sectional area, and tensile properties meet the requirements of ASTM A996.

8.3.2 Forms and Subgrade

- a. Forms shall be constructed to produce hardened concrete having the shape, lines, and dimensions shown on the drawings.
- b. Do not remove forms or disturb forms until the concrete has attained sufficient strength to safely support dead and live loads.
- c. Subgrade surfaces under concrete placements containing less than 25 percent material passing a No. 4 sieve shall be covered with 8 mil polyethylene film to protect concrete from loss of water.
- d. Lap joints at least 4 inches.
- e. Moisten subgrade before placement, but do not cause water to pond, nor muddy or soft spots to appear.

8.3.3 Placing

- a. Convey concrete to the point of final deposit by methods that will prevent the separation of materials.
- b. During and immediately after placement concrete shall be worked around reinforcement and embedments and worked into corners of the forms.
- c. During and immediately after placement thoroughly vibrate and consolidate concrete around reinforcements, embedments, and corners of forms.
 - Use mechanical vibrators that will maintain at least 9000 cycles per minute when immersed in concrete. Minimum horsepower per vibrator shall be 1½ hp.
 - Vibration of concrete will occur for an adequate length of time to obtain adequate consolidation (generally 5 to 15 seconds) without over-vibration causing the fines to separate. Do not use vibrators to transport concrete laterally in forms.
- d. Concrete shall not be placed unless the air temperature adjacent to the concrete placement is 32°F and rising. There shall not be any frost in the subgrade.

- e. Cease placement if the temperature is falling and drops below 40°F.
- f. The temperature of the mix shall not be less than 50°F, or more than 90°F at the time of the placement.
- g. If heated mixing water and/or an accelerator is used, the above temperature restrictions may be waived with prior written permission from the District.
- h. Water shall not be heated to a temperature exceeding 150°F.
- i. To facilitate the placement of concrete in hot weather, the aggregate and the water may be cooled.

8.3.4 Finishing

- a. Manhole bases, benches and inverts shall be true to line and grade and smoothed with a light broom finish.
- b. The entire top of cast-in-place manholes must be flat within 1/8-inch to ensure a complete seal with the barrel section above.

8.3.5 Curing

- a. Finished concrete shall be cured by protecting it against moisture loss, rapid temperature change, and from rain, flowing water and mechanical injury for a minimum of 72 hours after placement.
- b. Concrete shall be maintained at a minimum temperature of 50°F during the curing period.
- c. Contractor is responsible for protecting the concrete until Final Acceptance.

Chapter 9 – Precast Concrete

9.1 Scope

This chapter covers precast concrete for manhole bases, barrels, cones, tops and rings.

9.2 Materials

- 9.2.1 Barrels, bases, cone sections and flat slab tops of manholes shall conform to ASTM C478 and shall be made with Type V cement conforming to ASTM C150.
- 9.2.2 Reference Standard Drawing SS-1 to determine when manholes shall be conical or flat-top manholes. Cone sections shall be the eccentric type unless approved otherwise by the District.
- 9.2.3 Reinforcing materials shall conform to ASTM C478 and rebars shall be either Grade 40 or 60.
- 9.2.4 Minimum reinforcement for bases of manholes shall consist of welded wire fabric, 4x4 – W4xW4, reference ASTM C47 and ASTM A185.
- 9.2.5 Fine and coarse aggregate shall conform to ASTM C33.
- 9.2.6 Water shall be free from silt, organic matter, alkali, salts, and other impurities.
- 9.2.7 Requirements on grout, ring and cover, steps, and preformed plastic gaskets shall be as specified in Chapter 6.
- 9.2.8 Pipe penetrations shall include approved gasket devices.

9.3 Construction

- 9.3.1 **Product Delivery, Storage and Handling:** Precast concrete parts shall be handled, stored, and protected in a manner that will prevent damage.
- 9.3.2 **Preparation:** Reference Chapter 5 on Trenching for requirements on subgrade, stabilization material, and bedding.
- 9.3.3 **Construction:**
 - a. Vaults and manholes shall be set plumb and to grade.
 - b. Sections shall be joined using preformed plastic gaskets and joints shall be clean, dry and primed.
 - c. Lifting holes shall be filled with an approved non-shrink grout.

Chapter 10 – Adjustment of Manhole Rims

10.1 Responsibility

Any entity completing pavement repair or upgrades at or near District manholes shall be solely responsible for costs to adjust manholes to meet new surface grade, or for any repair to District manholes that occurs because of this work.

10.2 Notification

Any entity completing pavement repair or upgrades at or near District manholes shall notify the District when such work is being planned and notify the District again when such work commences. The District must inspect all manhole adjustments and requires a minimum of 2 working days notice before inspection occurs.

10.3 Description

- 10.3.1 This Chapter describes adjusting sanitary sewer manhole frames and furnishing all labor, materials, and other items necessary to bring the frames to the grades as shown on Standard Drawing SS-4 or as specified by the District Engineer.
- 10.3.2 Milling or grinding around manholes shall be accomplished with care to prevent damage to District property. Unless otherwise approved by the District Engineer, milling or grinding operations shall be carried to within one (1) foot of all manholes. The Contractor will be responsible for hand chipping the remaining one foot on all manholes.

10.4 Materials

- 10.4.1 Solid iron riser rings of the required height shall be used to adjust existing manhole frames to final grade; adjustable riser rings will not be accepted. The Contractor shall measure existing manhole frames to ensure ordering and placing riser rings with a compatible diameter of each manhole frame, which may vary from manhole to manhole. Riser rings shall be a minimum of 3/4" thick meeting ASTM A36 or A.I.S.I. 1020 Hot Rolled Steel. A maximum of one new adjusting ring may be used per manhole.
- 10.4.2 Precast grade rings may be installed above the manhole cone. A maximum of 16 inches of the combination of frame and grade rings are allowed, including existing grade rings. If this maximum must be exceeded to meet the new surface grade, the existing manhole cone shall be removed and new precast section(s) installed to District specifications.
- 10.4.3 Acceptable materials are listed in the Approved Materials List on the District website.

10.5 Construction Requirements

10.5.1 All manhole frames shall be reset accurately to line and grade by one of the following two methods:

- a. Remove the frame and lid and raise or lower with precast concrete grade rings. One pre-formed plastic gasket shall be placed between existing riser rings or manhole top and new grade rings. One preformed plastic gasket shall also be placed between subsequent grade rings and the manhole frame.

Or,

- b. Use one new non-adjustable riser ring fitted to the manhole frame. Placement of the adjusting ring shall occur immediately in advance of the paving operation. The Contractor shall install the riser ring according to the manufacturer's specifications. The grade of the lid shall be $\frac{1}{4}$ inch below the surrounding pavement and shall provide a smooth riding surface.

10.5.2 All frames shall be thoroughly cleaned of all accumulations of silt, clay, debris or foreign matter of any kind and shall be free from such at the time pavement is to be laid.

10.5.3 Flat metal manhole covers shall be temporarily placed immediately ahead of the paver so that the paver shall never pass over original manhole covers. A sufficient number of flat covers shall be available on the job site to allow the paving operation to progress smoothly. Once the ring area has been paved, the temporary manhole cover shall be removed and the original manhole cover placed on the ring. The Contractor shall fill in any needed asphaltic concrete to insure a proper, neat and long-lasting installation. The Contractor will be responsible for any repair or maintenance due to poor workmanship.

10.5.4 All manhole covers shall be cleaned and returned to their original condition after paving. No asphalt or debris shall be left on any lid or cover.

10.5.5 All installations shall be inspected and approved by the District Inspector.

10.6 Equipment

The Contractor shall provide the necessary tools and equipment to complete all work as described above.

Appendix A

Development and Construction Process

Appendix B

Development Drawing Checklist

(Common Drawing Issues)

This checklist is provided as a courtesy to expedite plans review and reduce comments iterations. However, use of this checklist does not guarantee full compliance with all District requirements.

Notes and Signatures	<input type="checkbox"/>	1) Sanitation District-specific signature block included, most recent version.
	<input type="checkbox"/>	2) Sanitation District-specific notes included, most recent version.
Plan Views	<input type="checkbox"/>	3) All existing utilities shown.
	<input type="checkbox"/>	4) Unused existing service line stubs called out for abandonment or specific future use.
	<input type="checkbox"/>	5) All easements and rights-of-way are shown.
	<input type="checkbox"/>	6) Sewer mains shown centered in easements.
	<input type="checkbox"/>	7) Plan and profile stationing correlate.
Profile Views	<input type="checkbox"/>	8) All utility crossings are shown.
	<input type="checkbox"/>	9) All manhole inverts are shown, <u>including existing</u> .
	<input type="checkbox"/>	10) Drops through manholes meet District requirements.
	<input type="checkbox"/>	11) Manhole depth _____.
Utility Crossings	<input type="checkbox"/>	12) Required clearance from all existing and planned utilities, or insufficient clearance mitigated.
	<input type="checkbox"/>	13) All sanitary sewer lines cross <u>beneath</u> water lines.
	<input type="checkbox"/>	14) Service lines meet separation requirements.
Details	<input type="checkbox"/>	15) All relevant details are included (District Standard Drawings).
	<input type="checkbox"/>	16) Details (District Standard Drawings) are legible and high resolution.

Appendix C

Standard Drawings

Flat slab top section (in lieu of conical top) designed to support overlying loads, including H-20 traffic.

Concrete adjustment rings

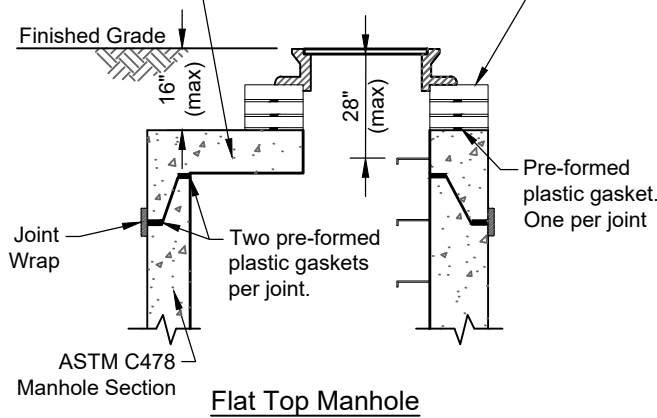

Flat Top Manhole

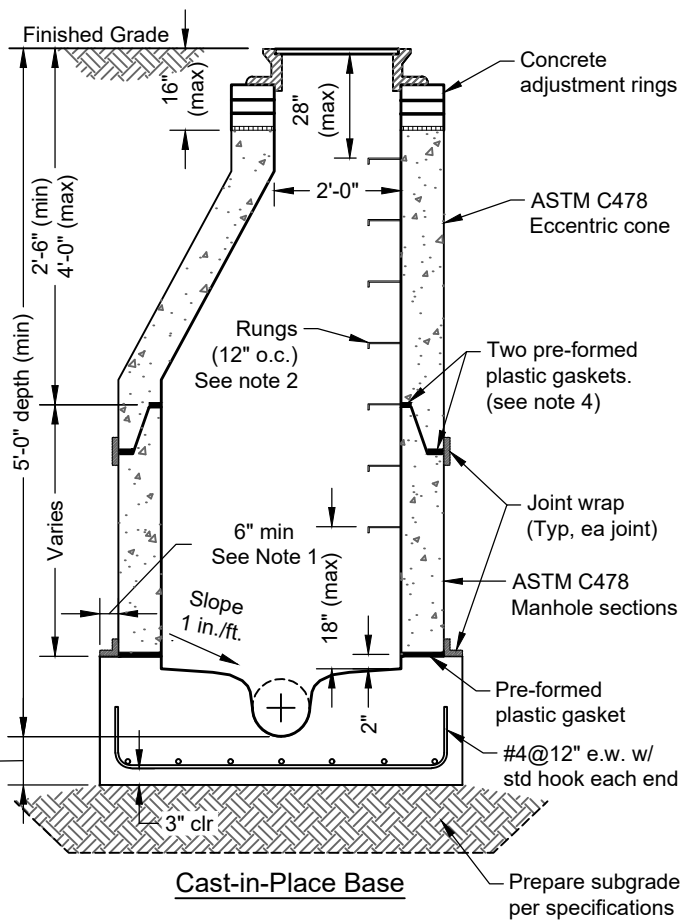

Cast-in-Place Base

MH < 15 ft : 8" min
MH > 15 ft : 12" min

Pipe Size	Manhole Diameter (min)	Manhole Wall Thickness (min)
15 in or less	48 in	5 in
18 in to 30 in	60 in	6 in
Over 30 in	72 in	7 in

Notes:

1. Base shall be at least 6" wider than barrel outside radius. Design engineer shall determine if a wider base is required to prevent flotation.
2. Manhole steps shall not be installed over any flow channel.
3. Pre-cast manhole base shall be sized and reinforced by manufacturer based on diameter and depth.
4. Lifting holes must be grouted, and if fully penetrating the barrel, must also be taped on the outside.

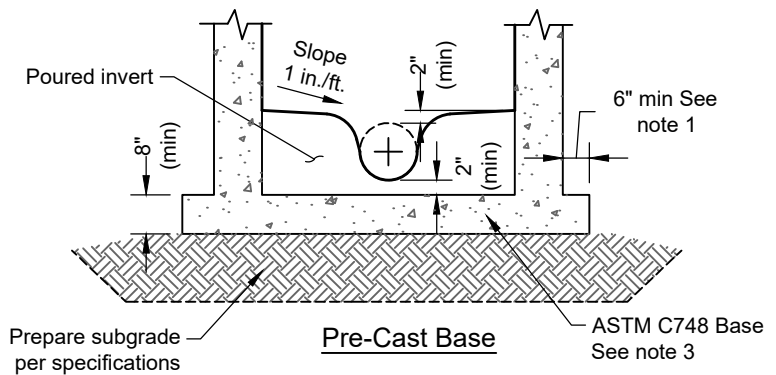

Pre-Cast Base



Standard Sanitary Sewer Manhole

SS-1

September 2023

Not to scale

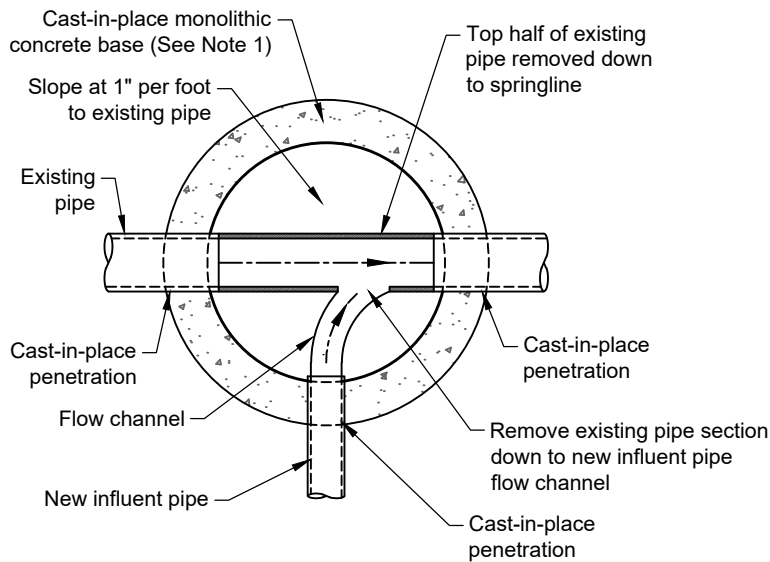
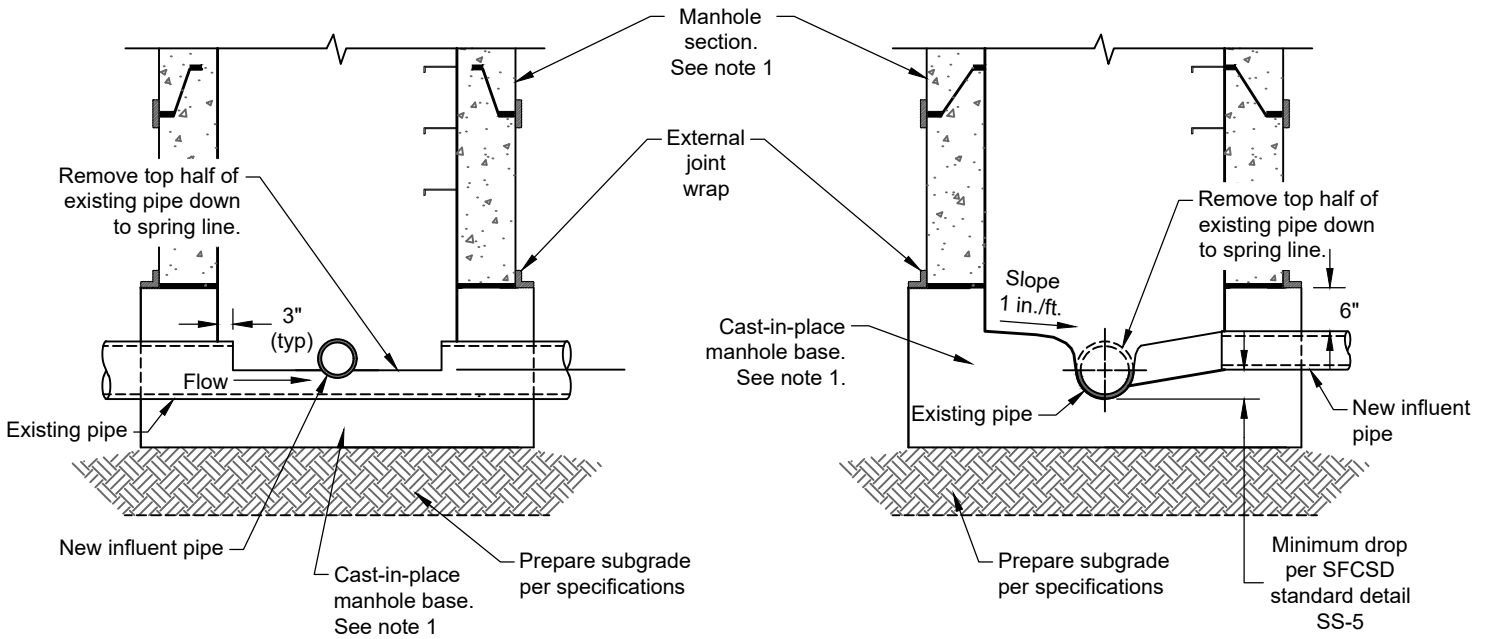

Notes:

1. Manhole shall meet all requirements of a standard cast-in-place manhole as shown on SFCSD standard detail SS-1.
2. New influent pipe diameter must not exceed existing pipe diameter.

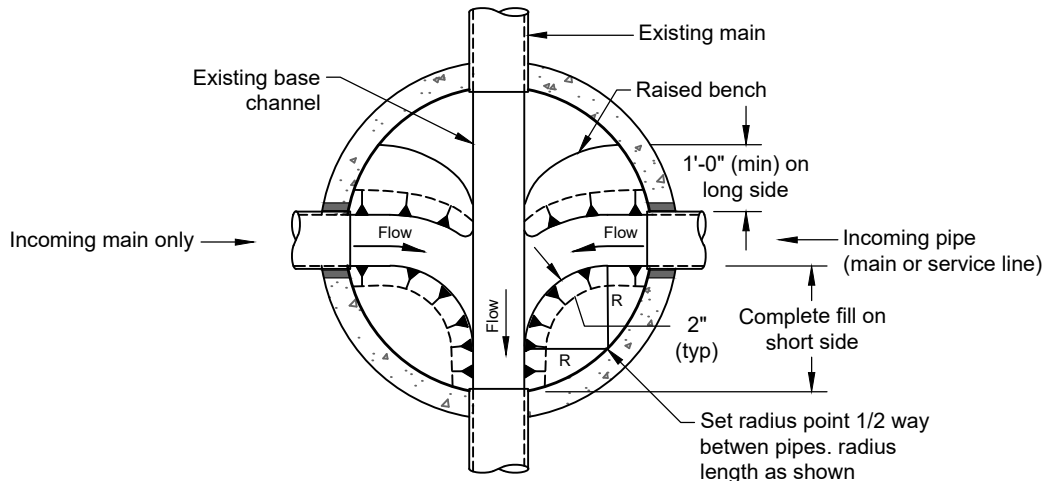

Plan View

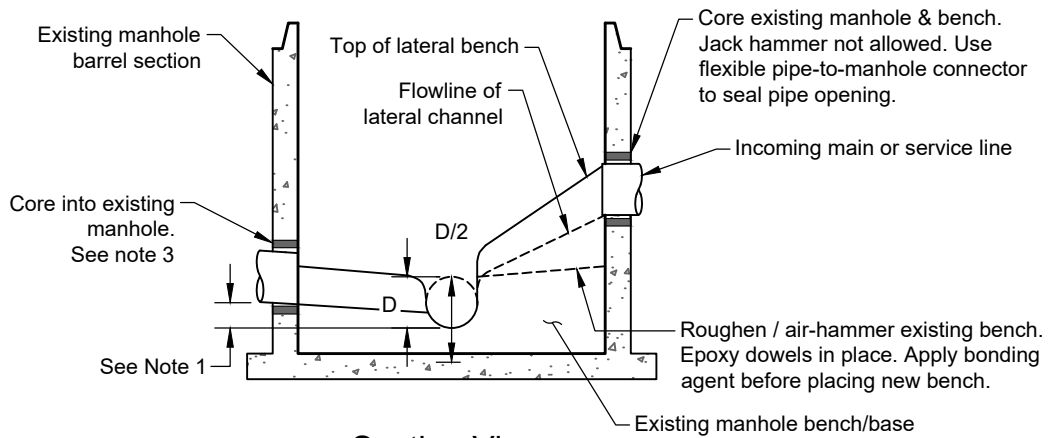

Section View

Notes:

1. Channels shall be concrete, shaped to fully contain the full height of the incoming pipe at the manhole wall, sloping to half the pipe diameter at the main channel.
2. Invert shaping shall be direct flow toward the downstream end of the manhole.
3. Core existing manhole. Jack hammering not allowed. Use flexible pipe to manhole connector to seal opening. Remove existing interior bench and repair benches and channels.
4. The District must verify the condition of the base after removal of the bench to determine if structural integrity has been compromised during removal. If structural integrity has been compromised, the entire base section shall be replaced.
5. See SFCSD standard detail SS-5 for required invert drops. Drop manholes shall be used for invert drops greater than 24" above the main channel bench.
6. Concrete shall be ready-mixed with a minimum 28-day compressive strength of 3000 psi.
7. Special permission must be received from the District before commencing any work on existing manholes.



Connection to Existing Manhole

SS-3

September 2023

Not to scale

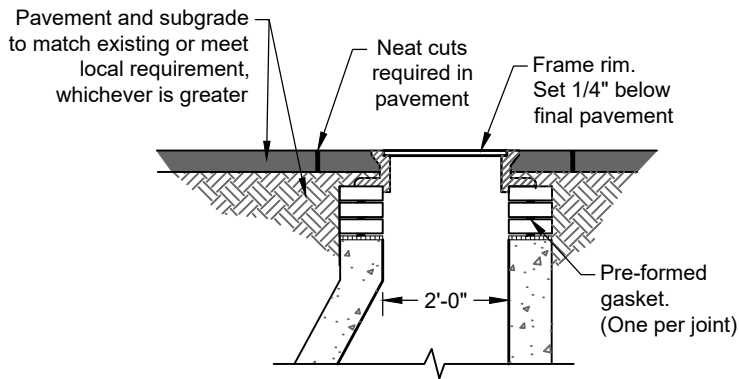

Manhole in Pavement

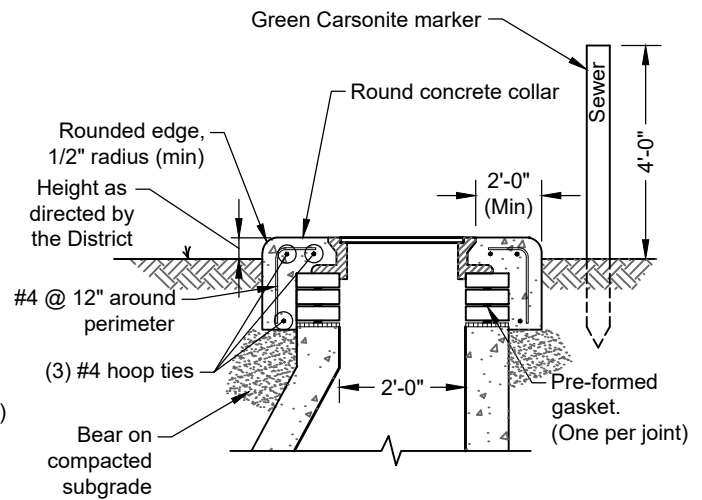

Manhole in Unpaved Areas

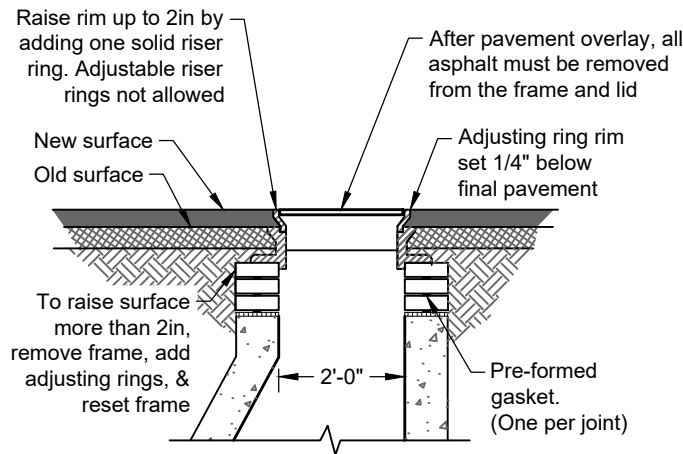

**Adjusting Manhole to Raised Grade
(Including Pavement Overlay)**

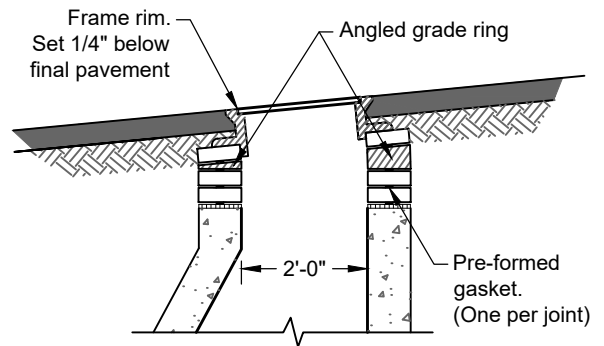

Manhole in Sloped Surface

Notes:

1. All pavement and subgrade shall, at a minimum, meet the requirements of the County, City, or Town having jurisdiction.
2. At a minimum, concrete thickness shall be:
 - a. For patios and sidewalks: 4 inches
 - b. For driveways, slabs, gutters, paver base and any driving surface: 6 inches
 - c. For cross pans: 8 inches
3. Adhesive is permitted to substitute for a gasket where synthetic grade rings are used.
4. All manhole assemblies to meet H-20 load rating at a minimum.



Manhole Surface Completions

SS-4

September 2023

Not to scale

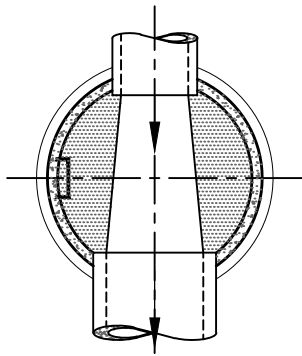

Through Pipe

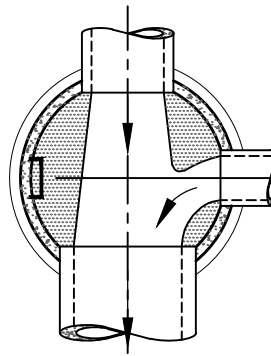

Through Pipe - One Lateral

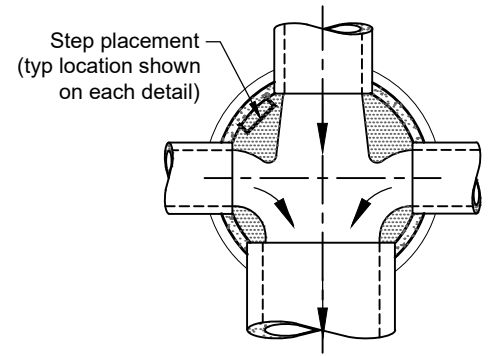

Through Pipe - Two Laterals

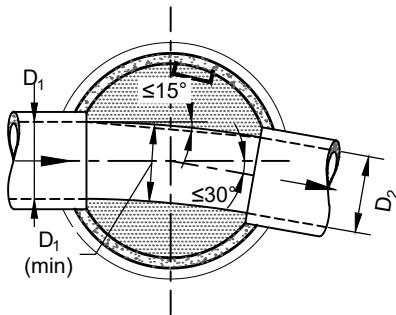

Slight Angle

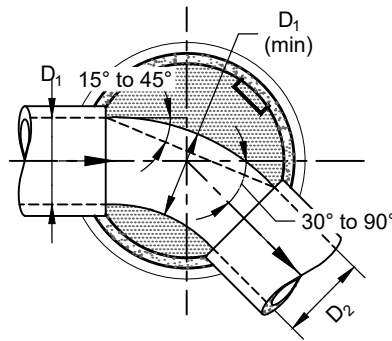

Medium Angle

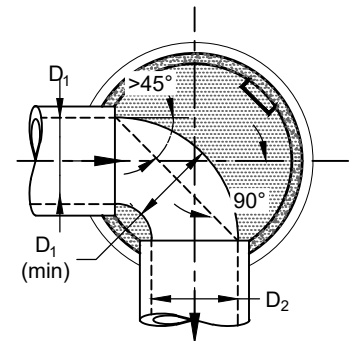

Sharp Angle

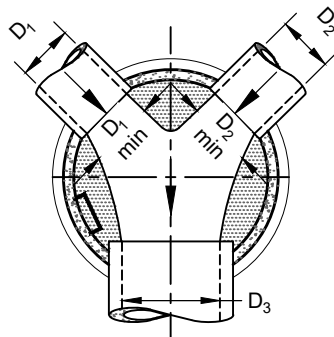

Angled Laterals

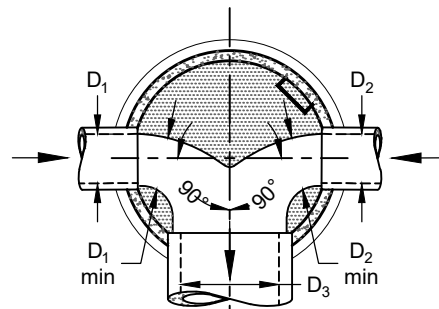

Opposed Laterals

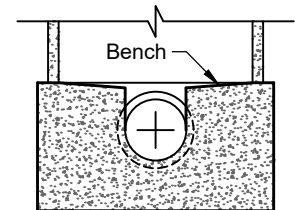

Ideal MH Channel Section

Notes:

1. Details shown are typical only for installations with all inverts at relative elevations within District specifications. For excessive elevation difference between inverts, etc., special base/channel details shall be shown on plans.
2. Vertical drops in excess of 2 feet require an outside drop.
3. Channels shall be formed smooth meeting the requirements in the District specifications.
4. All benches shall have a skid-resistant broom finish.
5. Elevation drop required between each inlet invert relative to outlet invert:
 - a. $< 45^\circ$, 0.1 ft
 - b. $45^\circ - 75^\circ$, 0.2 ft
 - c. $75^\circ - 90^\circ$, 0.3 ft

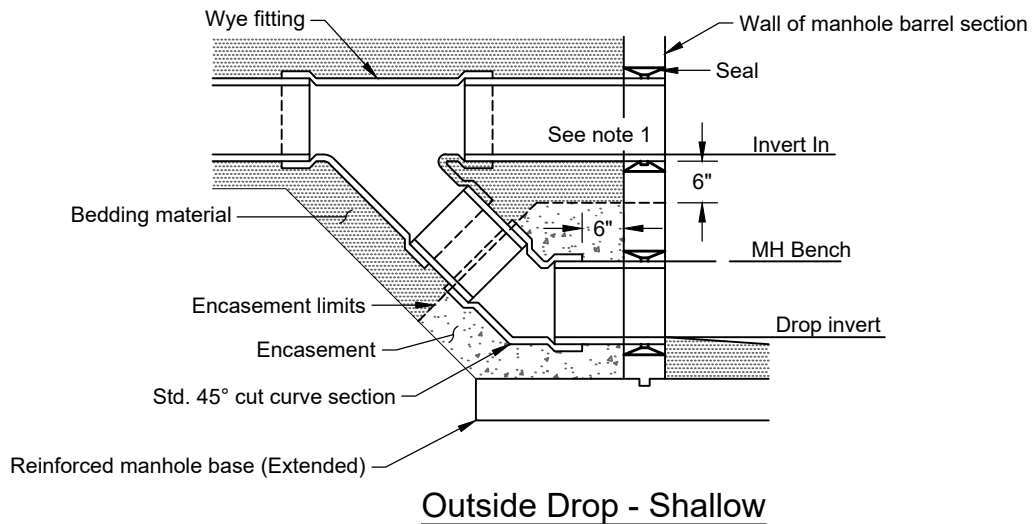
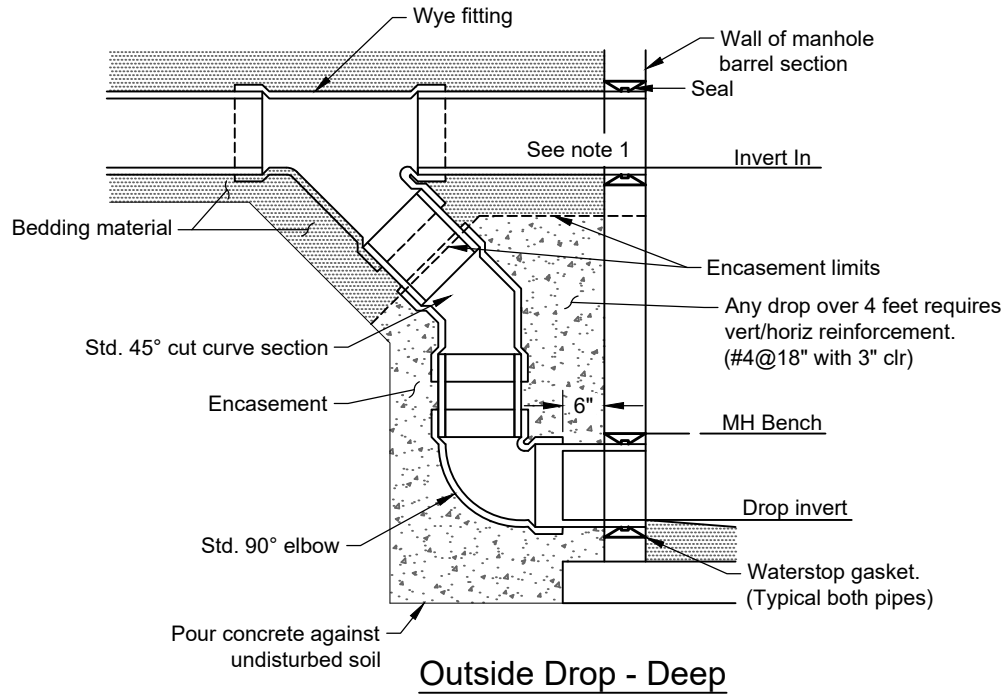

Notes:

1. **Jack-hammering is not allowed.** All manhole openings shall be precast block-outs or core drilled.
2. For 18in diameter and larger pipe, outside drops shall be a special design.
3. Outside drop shall be constructed of C900 PVC.
4. Concrete encasement shall be a minimum of 6 inches thick all around.
5. An outside drop is required for any drop greater than two feet.



Manhole Outside Drops

(Drop Through Manholes > 2 feet)

SS-6

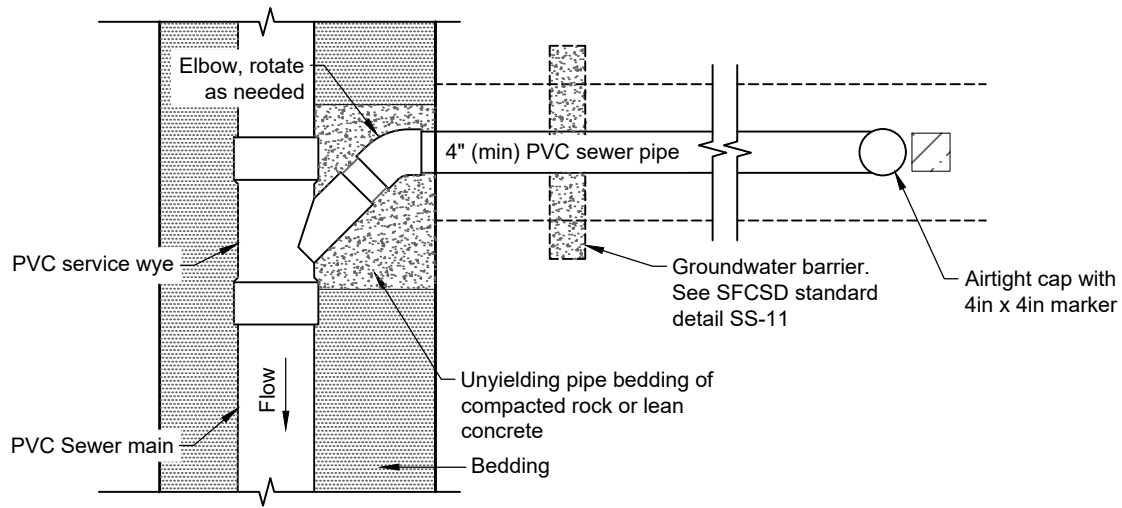

Plan View

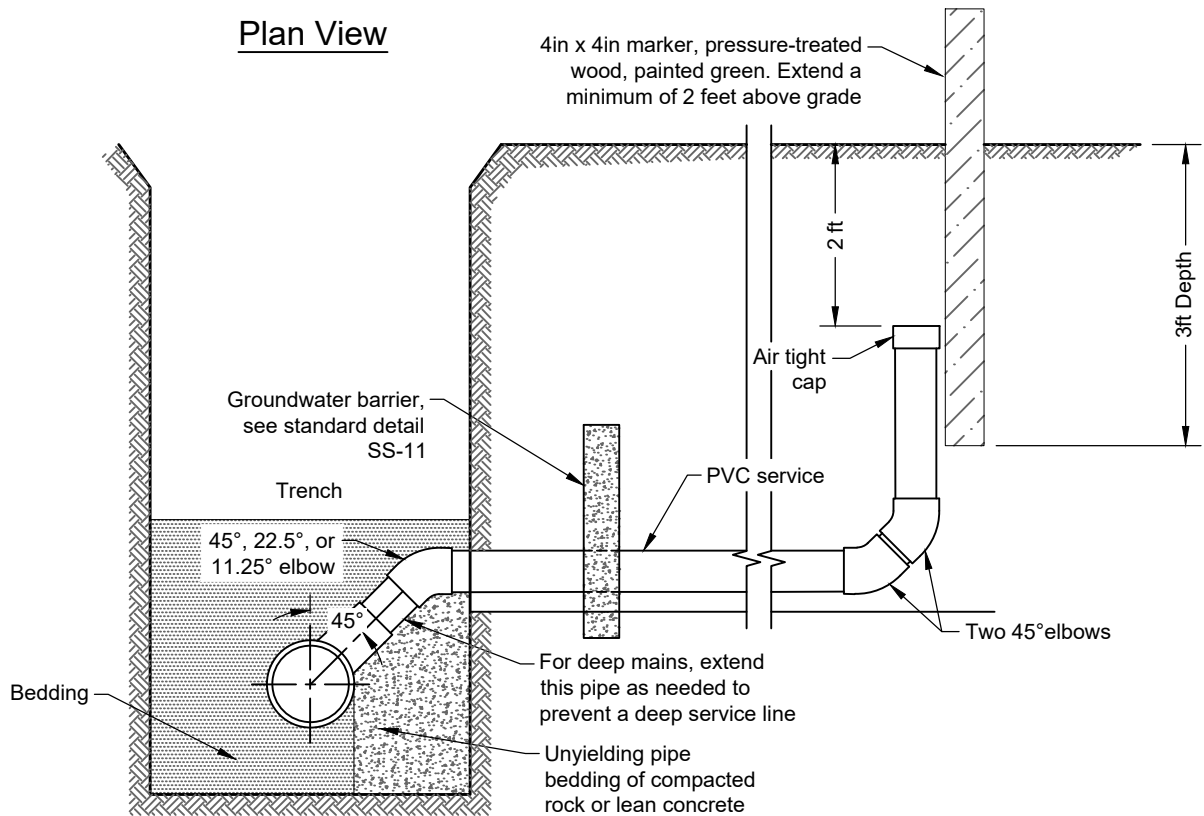

Section View

Notes:

1. Services shall be no closer than three feet from other service connections, or from bell or spigot end of sewer main pipe.
2. 4in sewer service minimum slope: 2%
3. 6in sewer service minimum slope: 1%
4. Service line shall be constructed on the shortest and straightest route possible with a minimum of one cleanout per 100 ft. See standard detail SS-9.
5. Sewer service lines shall be no closer than 10ft horizontally from any water service lines.
6. The District shall observe all service connections to the main, including the service support bedding, before burial. Schedule with the District at least three working days in advance.



Service - New Construction

SS-7

September 2023

Not to scale

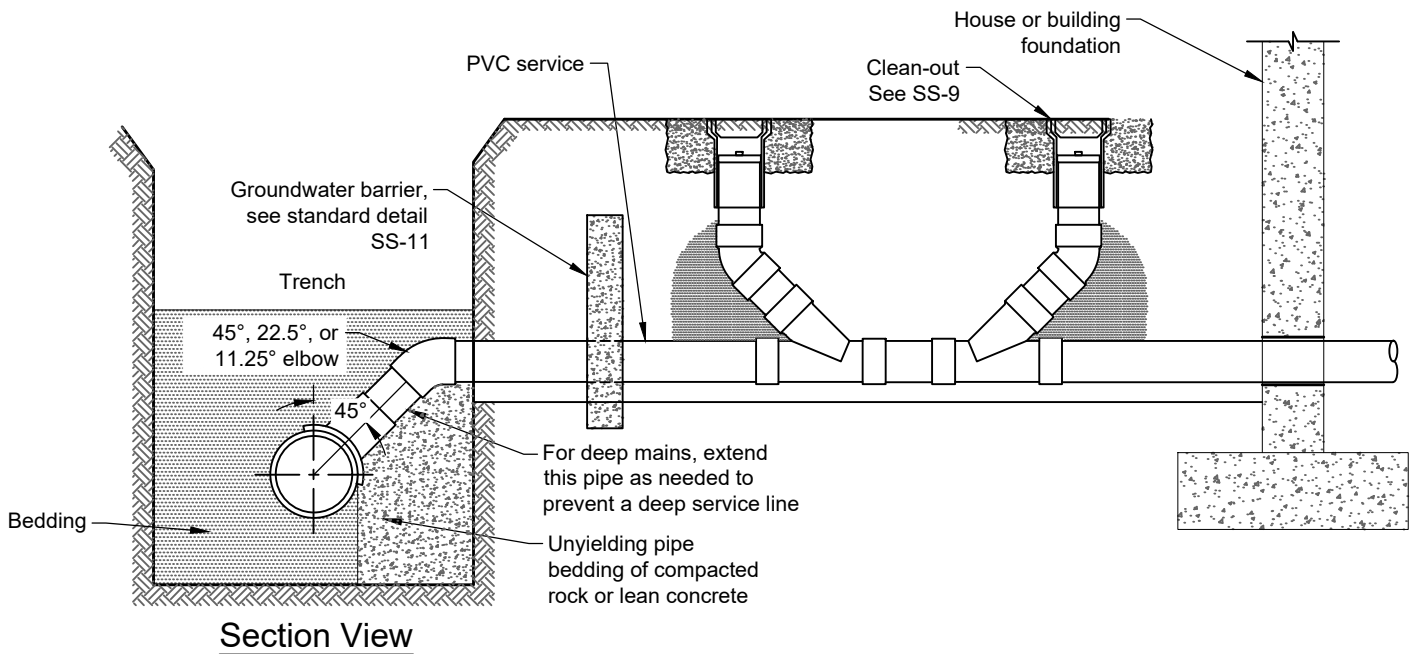
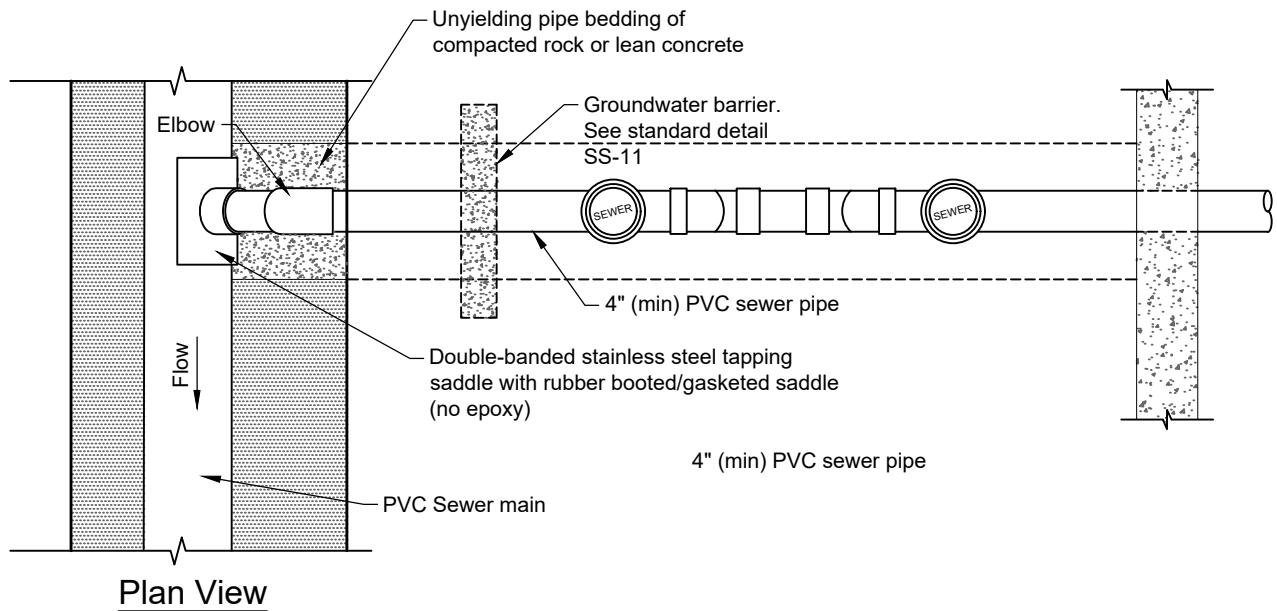

Notes:

1. Services shall be no closer than three feet from other service connections, or from bell or spigot end of sewer main pipe.
2. 4in sewer service minimum slope: 2%
3. 6in sewer service minimum slope: 1%
4. Service line shall be constructed on the shortest and straightest route possible with a minimum of one cleanout per 100 ft. See standard detail SS-9.
5. Sewer service lines shall be no closer than 10ft horizontally from any water service lines.
6. The District shall observe all service connections to the main, including the service support bedding, before burial. Schedule with the District at least three working days in advance.
7. Tapping saddle bands shall be fully stainless steel, including band, screw, and screw cage.



Service - Connection to Existing Main

SS-8

September 2023

Not to scale

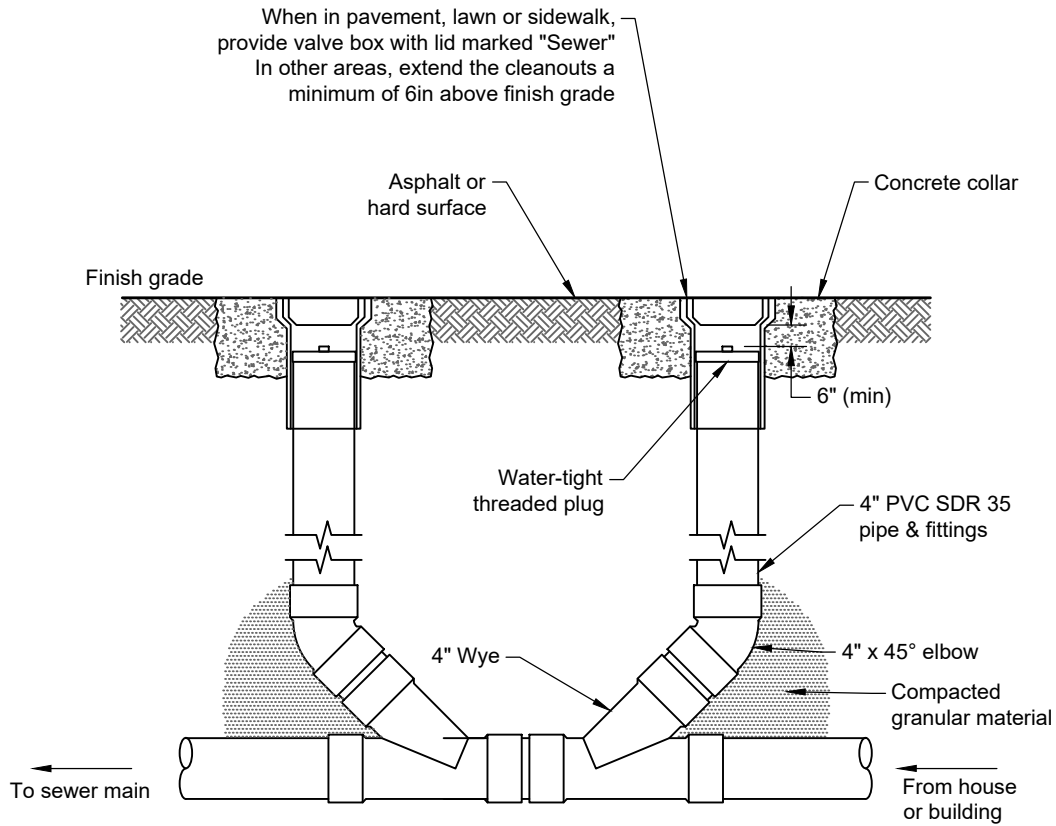

Section View

Notes:

1. Sewer service clean-outs shall be installed as near as practical to connection with the building, and additional cleanouts at a maximum spacing of 100ft. No single bend greater than 45° shall be allowed.
2. Clean-outs shall meet all requirements of the latest version of the International Plumbing Code.
3. A complete clean-out assembly includes both wyes and risers shown above.

Trench Width (note 4)		
Pipe Diameter	Minimum Width	Maximum Width
4"	1'-4"	2'-4"
6"	1'-6"	2'-6"
8"	1'-8"	2'-8"
12"	2'-0"	3'-0"
16"	2'-4"	3'-4"
20"	2'-8"	3'-8"
24"	3'-0"	4'-0"
> 24"	Engineered	Engineered

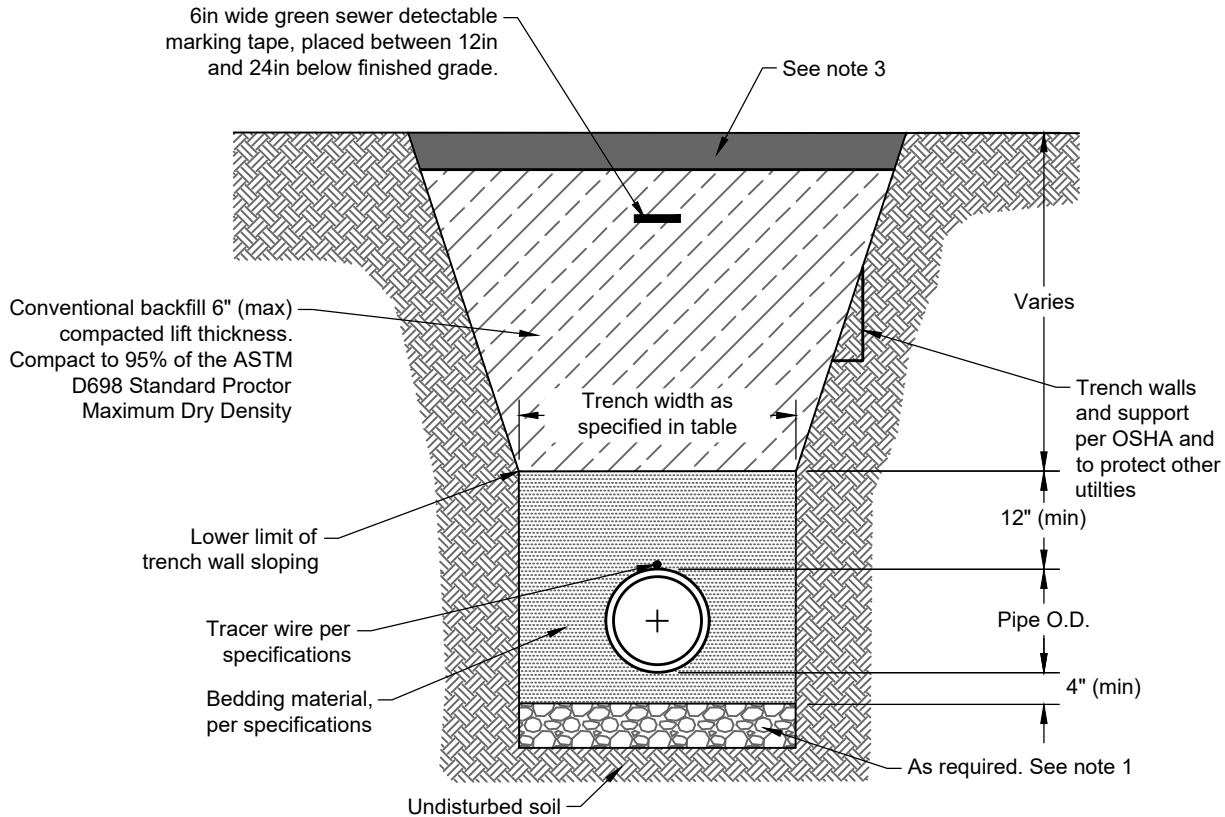

- Notes:**
1. Stabilization material may be required to replace a determined depth of the pipe subgrade. Install geotextile fabric between the stabilization material and pipe bedding.
 2. Where the surrounding soils are non-expansive, flowable fill meeting District requirements may be substituted for backfill material.
 3. Surface restoration to match existing conditions or re-pavement requirements of the applicable state, county, city or town.
 4. Trench widths exceeding maximums require a concrete cradle and/or arch design approved by the District.



Sanitary Sewer Main Trench Requirements

SS-10

September 2023

Not to scale

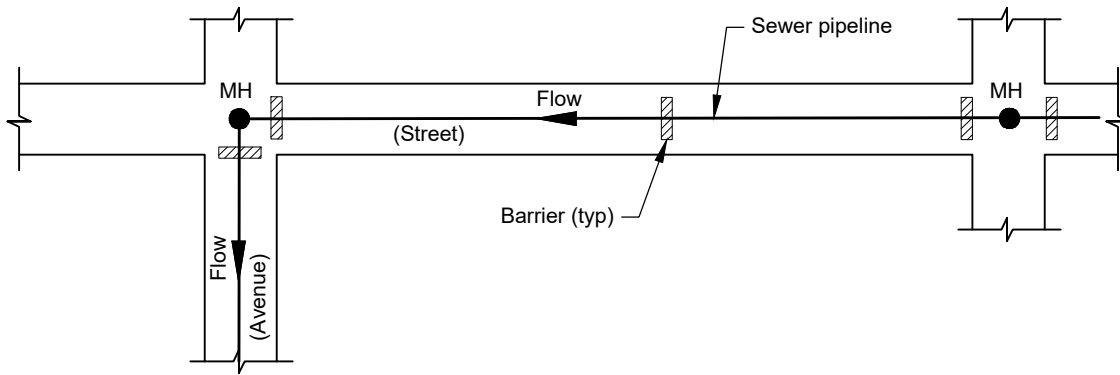

Typical Groundwater Barrier Layout

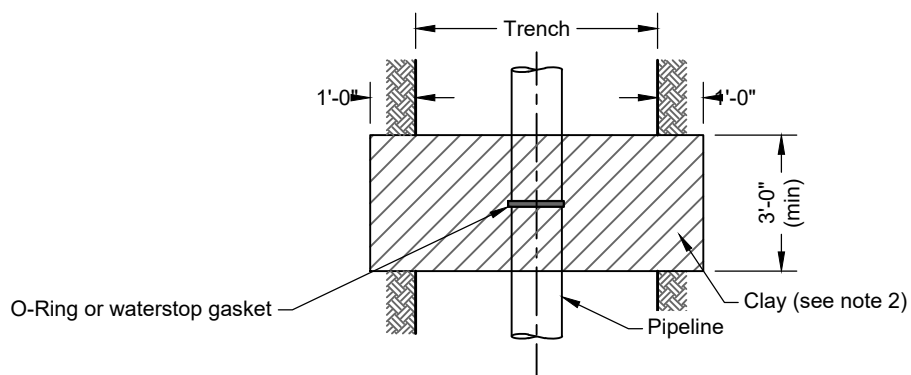

Plan View

Top of Clay Wall shall be the maximum of:

1. One foot above top of pipe bedding
2. Two feet above top of pipe
3. Two feet above maximum seasonal groundwater table elevation as determined by the Design Engineer

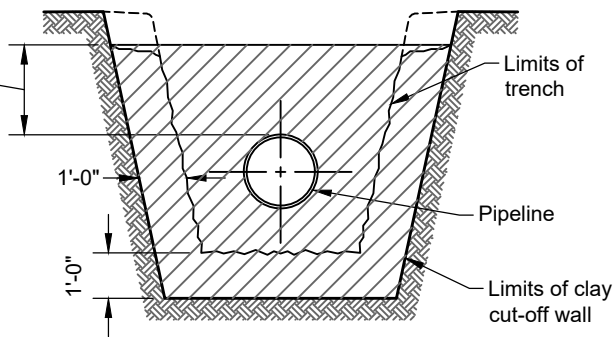

Section View

Notes:

1. Clay wall extends a minimum of 1'-0" into undisturbed soil on each side and on bottom of trench.
2. Acceptable clay material classified as SC, CL, or CH.
3. 3000psi concrete may be used instead of clay material, if a reinforcement design is approved by the District.
4. Nominal spacing is ± 300 feet, typically at midblock, on each service line, and each side of cross street, or as specified on plans or as directed by the state, county, city or town.
5. Add barriers on steep slopes as needed to prevent groundwater surfacing under all groundwater conditions.

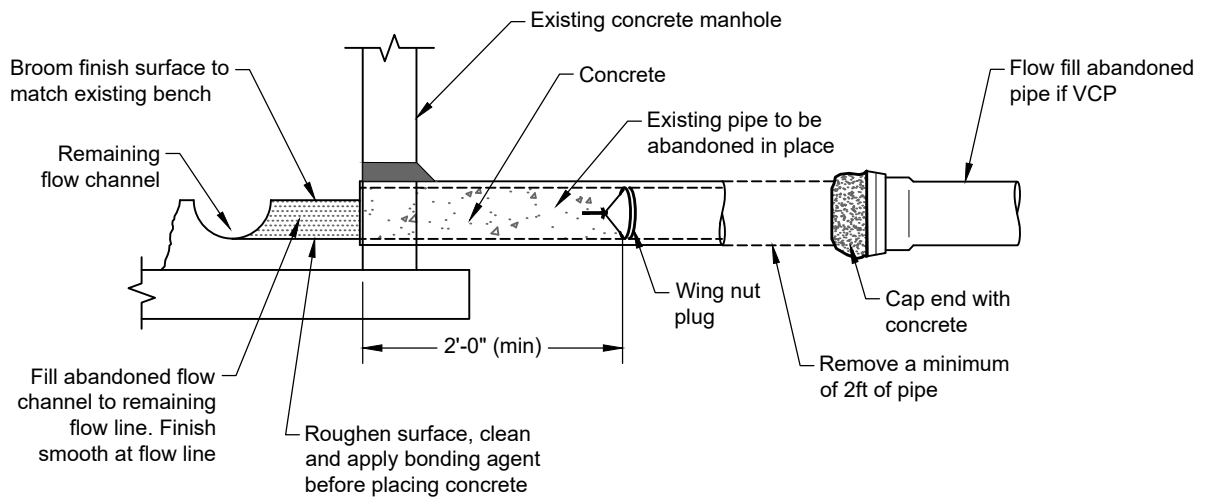

Sewer Main Abandonment

Sanitary Sewer Main Abandonment Notes:

1. Existing sanitary sewer mains and services abandoned in manholes shall have a wing nut plug placed 2 feet outside of manhole & have concrete placed from inside the manhole to the wing nut plug.
2. Abandoned flow channels in manholes shall be filled as noted on the drawing.
3. Any vitrified clay pipe (VCP) shall be flow filled completely. All other pipe materials shall be capped on both ends with concrete.
4. Sanitary sewer main abandonment must be scheduled with the District at least three working days in advance.

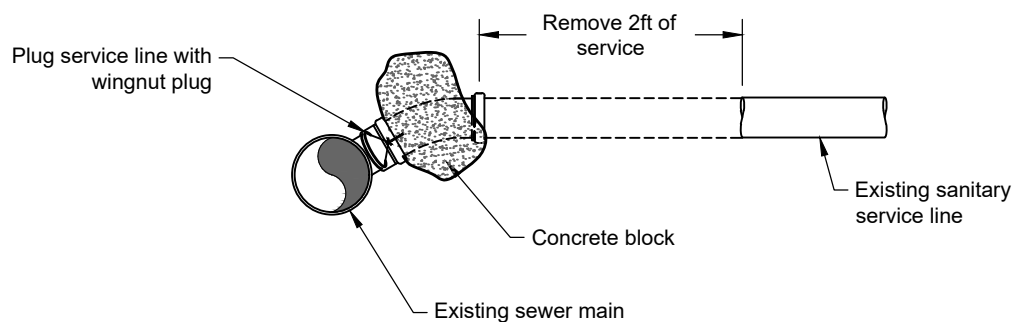

Sewer Service Abandonment

Sanitary Sewer Service Abandonment Notes:

1. All sewer services shall be plugged at the sewer main.
2. Contractor to install concrete block behind the wing nut plug.
3. Sanitary sewer service abandonment must be scheduled with the District at least three working days in advance.

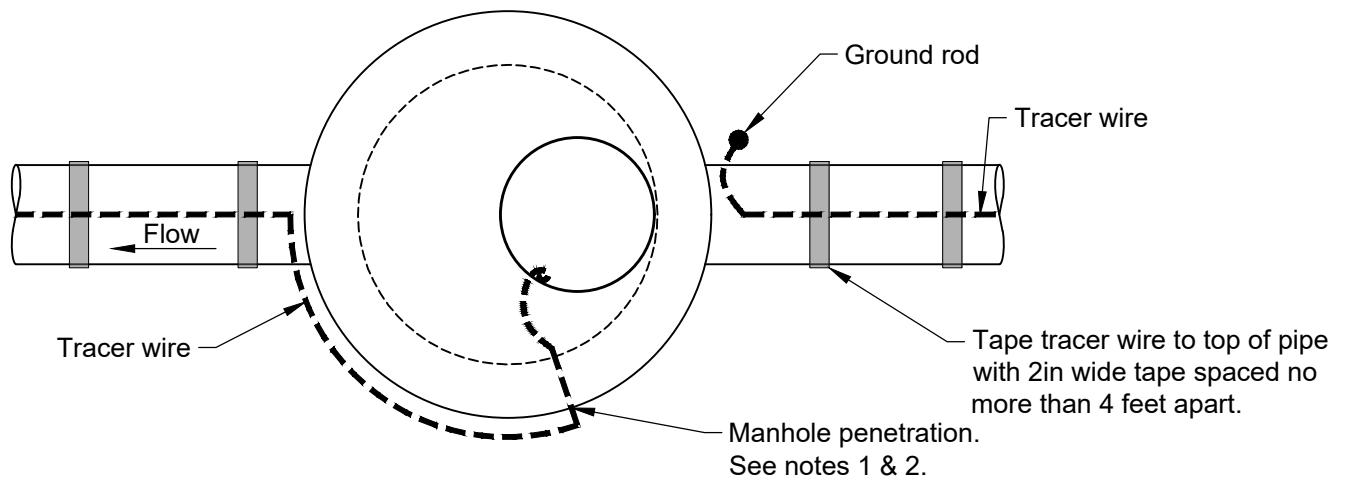
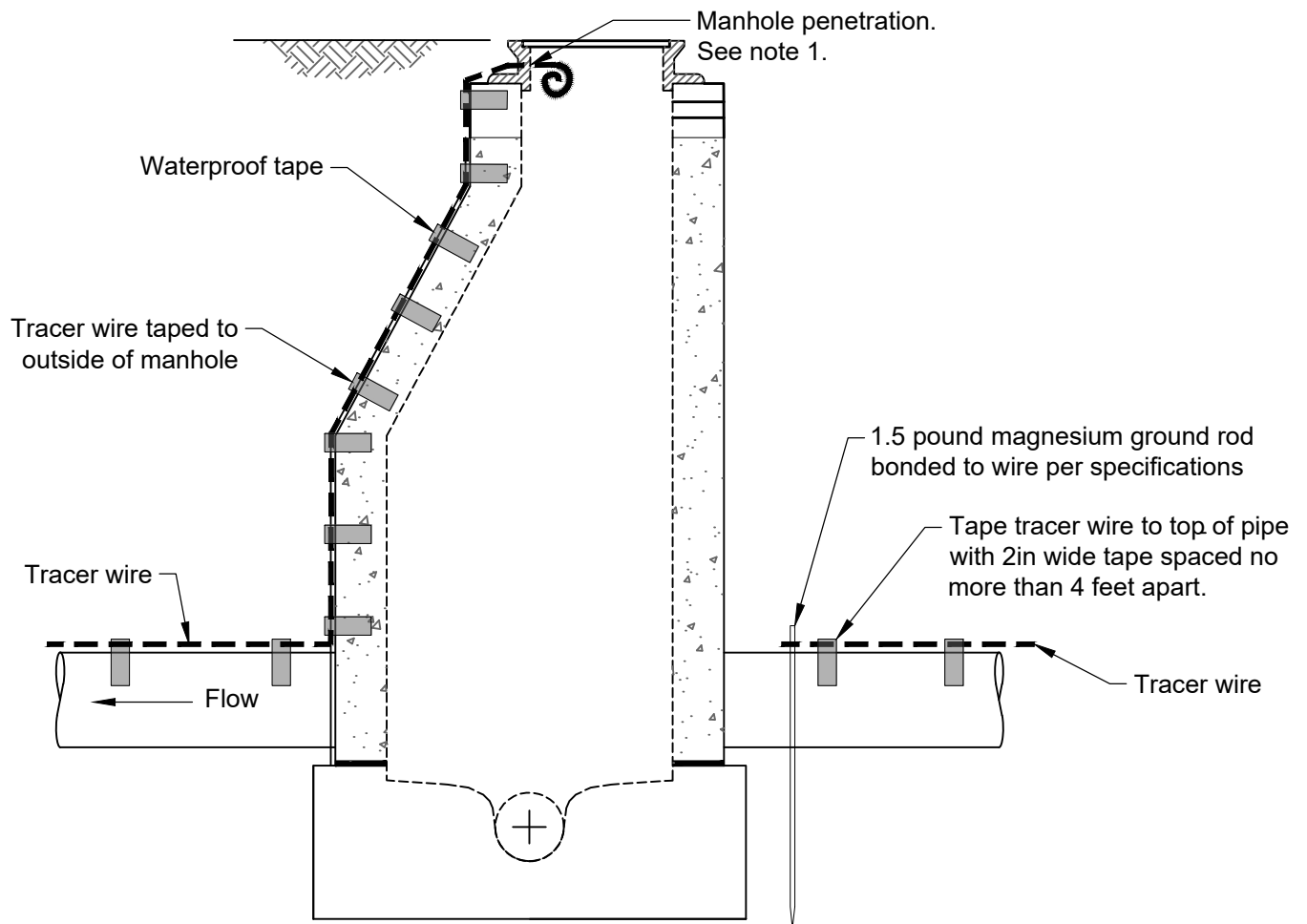

Notes:

1. Wire to penetrate through steel manhole frame via a 1/4" drilled hole below the lid support and extend 12 inches into the manhole. The wire must have green insulation with only 1 inch stripped. Wire must not penetrate manhole frame above the stairs.
2. Manhole penetration to be no more than 1/4 inch diameter hole, filled with pliable gasket material and covered with waterproof tape.
3. Tracer wire system must meet the requirements of Senate Bill 18-167 or any update.

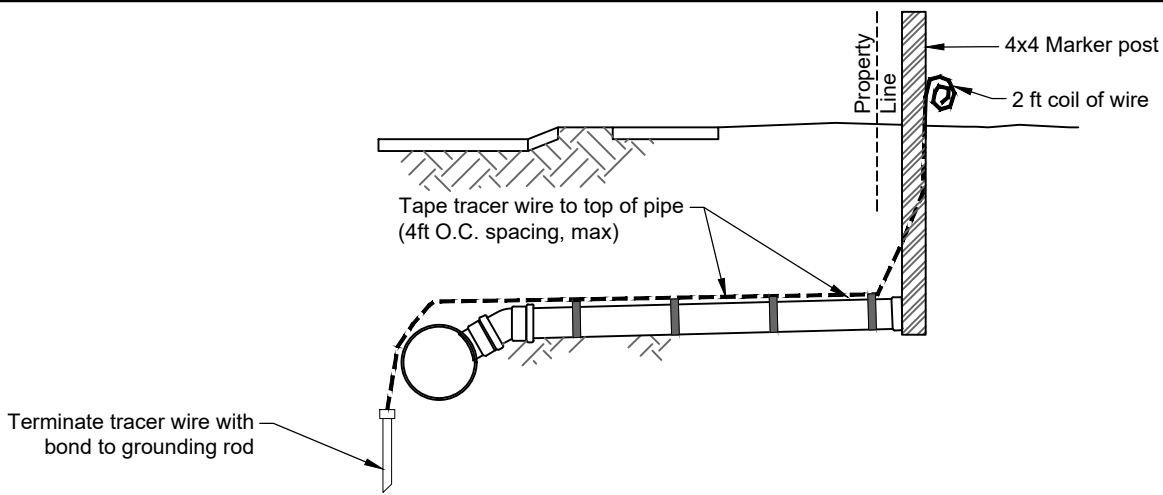

Tracer Wire Installation - Development

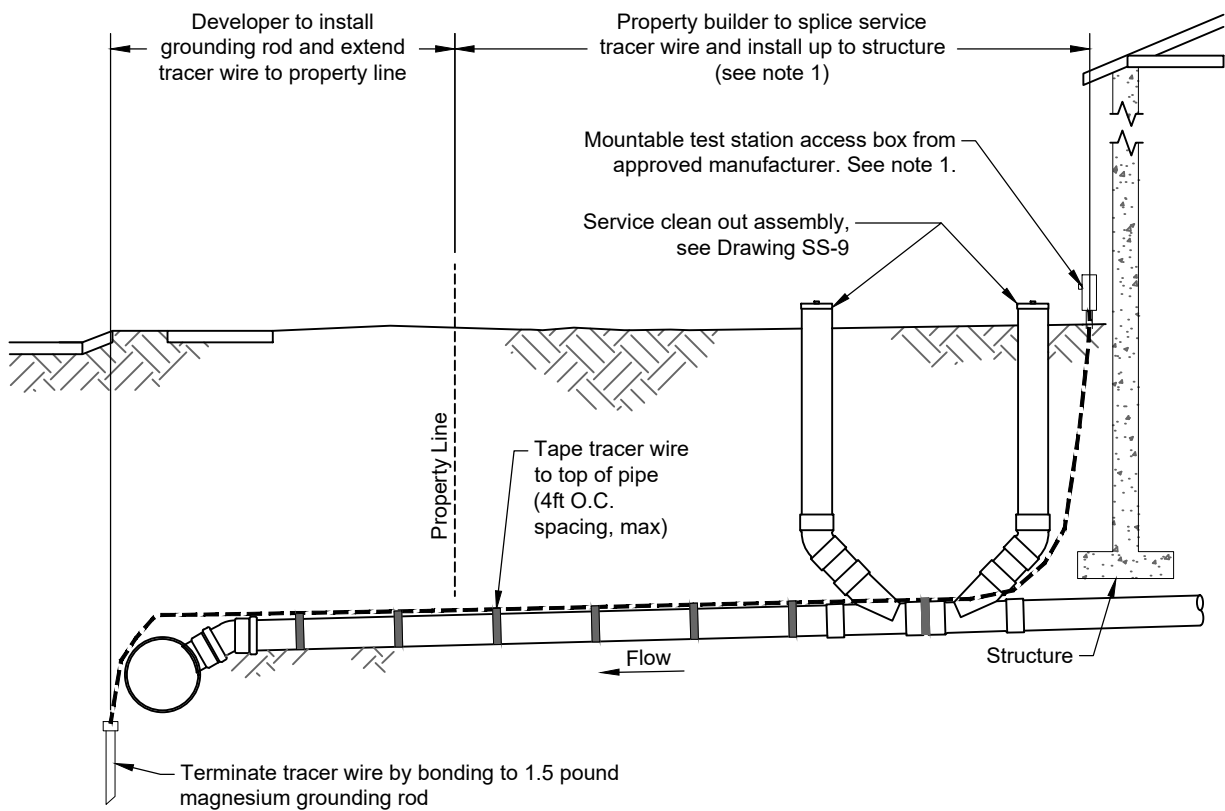

Tracer Wire Installation - Building Construction

Notes:

1. Property builder to splice sanitary sewer service tracer wire at the property line and install up to structure, terminating at the service cleanout with an approved test station access box. Test station access box shall be mounted to the structure within 18" of the SS service cleanout and installed according to the test station manufacturer specifications.
2. Tracer wire system must meet requirements of Senate Bill 18-167 or any update.